

SMART  
**SENSOR**  
BUSINESS

**MD 748i**  
**MD 248i**

PROFINET IO-Link Master



CONNECTING AND OPERATING INSTRUCTIONS

Original Instructions

© 2016

Leuze electronic GmbH + Co. KG

In der Braike 1

D-73277 Owen / Germany

*Trademark Notices*

Microsoft and Windows are registered trademarks of Microsoft Corporation.

Other product names mentioned herein may be trademarks and/or registered trademarks of their respective owners.

First Edition, February 24, 2016

Copyright © 2016. Leuze electronic.

All Rights Reserved.

Leuze electronic makes no representations or warranties with regard to the contents of this document or to the suitability of the Leuze electronic product for any particular purpose. Specifications subject to change without notice. Some software or features may not be available at the time of publication. Contact your reseller for current product information.

<b>1</b>	<b>Introduction .....</b>	<b>6</b>
1.1	PRODUCT DESCRIPITON .....	6
1.2	KEY FEATURES AND BENEFITS .....	6
<b>2</b>	<b>Hardware Installation.....</b>	<b>8</b>
2.1	Setting the Rotary Switch (IP67 Model) .....	8
2.1.1	MD 748i-11-42/L5-2222 - Setting the Rotary Switch.....	9
2.2	Connecting to the Network .....	9
2.2.1	MD 748i-11-42/L5-2222 - Connecting to the Network .....	9
2.2.2	MD 248i-12-8K/L4-2R2K - Connecting to the Network .....	10
2.3	Connecting the Power .....	10
2.3.1	MD 748i-11-42/L5-2222 - Connecting the Power .....	10
2.3.2	MD 248i-12-8K/L4-2R2K - Connecting the Power .....	12
2.4	Mounting the IO-Link Master.....	13
2.4.1	MD 748i-11-42/L5-2222 - Mounting.....	13
2.4.2	MD 248i-12-8K/L4-2R2K - Mounting .....	13
<b>3</b>	<b>Configuring the IO-Link Master with STEP 7.....</b>	<b>14</b>
3.1	Overview .....	14
3.2	Installing the GSD File (STEP 7 V5.5) .....	14
3.3	Configuring the IO-Link Master (STEP 7 V5.5).....	14
3.4	IP Address Assignment.....	15
3.4.1	Assigning an IP Address via IO Controller (DCP) .....	15
3.4.2	Assigning an IP Address via DHCP .....	17
3.4.3	Assigning an IP Address Statically (LOCAL).....	18
3.5	Device Name Assignment .....	22
3.5.1	Assign the Device Name in STEP 7 .....	22
3.5.2	Using the Web Interface to Assign the Device Name.....	23
3.6	Setting the IO Device Update Time.....	24
3.7	Configuring IO-Link Ports.....	25
3.7.1	IO-Link Port Modules.....	25
3.7.2	Port Status Modules .....	29
3.7.3	Configuring IO-Link Ports with the Web Interface .....	31
<b>4</b>	<b>IO-Link Master Device Configuration .....</b>	<b>36</b>
4.1	Setting User Accounts and Passwords .....	36
4.2	Configuring Miscellaneous Settings .....	38
<b>5</b>	<b>Updating Images and Applications .....</b>	<b>40</b>
5.1	Images and Application Subassemblies Overview .....	40
5.1.1	Images.....	40
5.1.2	Application Subassemblies .....	41
5.2	Using the Web Interface to Update Software.....	41
5.2.1	Updating Images .....	41
5.2.2	Updating Application Subassemblies .....	42

- 6 Connecting Devices ..... 44**
  - 6.1 Connecting Devices to IO-Link Ports ..... 44
    - 6.1.1 MD 748i-11-42/L5-2222 IO-Link Ports..... 44
    - 6.1.2 MD 248i-12-8K/L4-2R2K IO-Link Ports ..... 45
  - 6.2 Connecting Devices to the Digital IO Ports (MD 248i-12-8K/L4- 2R2K) ..... 46
    - 6.2.1 Connecting to DI ..... 47
    - 6.2.2 Connecting to DIO..... 47
  
- 7 Dedicated Digital I/O Port Configuration..... 48**
  - 7.1 Digital I/O Settings Page ..... 48
  - 7.2 Editing Digital I/O Settings..... 48
  - 7.3 Digital I/O Setting Parameters..... 49
  
- 8 Loading and Managing IODD Files ..... 52**
  - 8.1 IO-Link Device Description Files Page..... 52
    - 8.1.1 Preparing IODD Files to Upload ..... 52
    - 8.1.2 Uploading IODD Zip Files ..... 53
    - 8.1.3 Uploading xml Files or Supporting Files ..... 55
    - 8.1.4 Viewing and Saving IODD Files..... 56
    - 8.1.5 Deleting IODD Files ..... 57
  - 8.2 IO-Link Device Configuration Summary Page ..... 58
  
- 9 Configuring IO-Link Devices ..... 60**
  - 9.1 Port Pages Overview ..... 60
  - 9.2 Editing Parameters - IO-Link Device - Port Table..... 60
  - 9.3 Resetting IO-Link Device Parameters to Factory Defaults ..... 62
  - 9.4 Editing Parameters - IO-Link Device ISDU Interface - Port..... 64
  
- 10 Utilizing IO-Link Master Features..... 68**
  - 10.1 Data Storage..... 68
    - 10.1.1 Uploading Data Storage to the IO-Link Master ..... 68
    - 10.1.2 Downloading Data Storage to the IO-Link Device..... 69
    - 10.1.3 Automatic Device Configuration ..... 69
    - 10.1.4 Automatic Device Configuration Backup ..... 70
  - 10.2 Device Validation ..... 71
  - 10.3 Data Validation ..... 73
  - 10.4 Using the Menu Bar Hover Shows Submenu Option..... 74
  - 10.5 IO-Link Test Event Generator ..... 75
  
- 11 Using the Diagnostics Pages ..... 77**
  - 11.1 IO-Link Port Diagnostics..... 77
  - 11.2 Digital I/O Diagnostics..... 79
  - 11.3 PROFINET IO Diagnostics Page..... 80
  
- 12 PROFINET IO Reference Information..... 82**
  - 12.1 Sample IO-Link Master Gateway Configuration..... 82

12.2	Read PDI Data as Record Data .....	83
12.3	Using the SFB52 RDREC .....	84
12.4	Read and Write ISDU with the FB IOL_CALL .....	85
12.5	Diagnostic Alarm .....	87
12.5.1	IO-Link Event Mapping Overview .....	87
12.5.2	IO-Link EventCode Mapping.....	87
<b>13</b>	<b>Troubleshooting and Technical Support.....</b>	<b>90</b>
13.1	Troubleshooting .....	90
13.2	IO-Link Master LEDs .....	90
13.2.1	MD 748i-11-42/L5-2222 .....	90
13.2.2	MD 248i-12-8K/L4-2R2K.....	91
13.3	Contacting Technical Support.....	92
13.4	Using Log Files.....	94
13.4.1	View a Log File.....	94
13.4.2	Export a Log File .....	95
13.4.3	Clear a Log File .....	96
<b>14</b>	<b>TYPE / SPECIFICATION.....</b>	<b>97</b>
14.1	MD 748i-11-42/L5-2222.....	97
14.2	MD 248i-12-8K/L4-2R2K .....	98

## 1 Introduction

### 1.1 PRODUCT DESCRIPTION

The Leuze electronic IO-Link Master combines the benefits of the IO-Link standard with the popular industrial PROFINET IO protocol by providing a gateway that is a streamlined bridge between the field level sensor network and the industrial PROFINET IO backbone, making retrofitting or expansion simple.

The MD 748i IO-Link Master features a rugged IP67 slim-line design incorporating two Fast Ethernet ports and four IO-Link ports with Class A M12 connectors.

This product is designed for industrial applications with its machine mount design using industrial grade components.

The MD 248i IO-Link Master easily installs on a standard DIN rail and incorporates two Fast Ethernet ports, eight IO-Link ports, two DI/DO ports and two DI ports.

This product is designed with industrial grade components and redundant power inputs to make it exceptionally reliable for critical applications.

The Leuze electronic IO-Link Masters are easily integrated into factory automation networks and are compatible with both IO-Link and digital IO sensor technologies.

### 1.2 KEY FEATURES AND BENEFITS

- MD 748i
  - Four channel IO-Link Master to PROFINET IO
  - Rugged IP67 housing designed for harsh environments, M12 connectors allowing up to four sensor connections on one master block
  - Wide operating temperature (0° to +55°C)
- MD 248i
  - Eight port IO-Link Master to PROFINET IO with additional digital inputs on every port allowing for a possible 10 DI ports with two dedicated DI/DO ports
  - Screw terminal connectors for IO-Link, Power, and Digital IO
  - IP20 DIN rail mount enclosure
  - Wide operating temperature (-40° to +70°C)
- Powerful web GUI for configuration and diagnostics, including:
  - IO-Link device management using the IO-Link device manufacturers IODD file for easy device configuration
  - Automatic data storage (upload and download)
  - Manual data storage (upload and download)
  - Device validation
  - Data validation
- IO-Link V1.0 and V1.1 compatibility
- IO-Link COM1, COM2 and COM3 support (up to 230K baud rate)
- PLC access to IO-Link ISDU blocks without complex programming
- PROFINET Certification

This document provides installation, configuration and embedded web interface information for the Leuze electronic Profinet IO-Link Master.

The web interface provides a platform so that you can easily configure, review diagnostic pages, and access advanced features, such as the ability to:

- Set up user accounts with different user levels and passwords
- Load IODD files and configure IO-Link device parameters
- Implement manual or automatic data storage (upload or download)
- Implement device and/or data validation

The IO-Link Master installation includes the following procedures.

1. Connect the power and Ethernet cable.
2. MD 748I-11-42/L5-2222: If desired, set the rotary switch.  
*Note: Optionally, you can configure the IP address using the embedded web interface.*
3. Configure PROFINET IO.
4. If necessary, upload the latest images for the latest features.
5. Connect the IO-Link and digital I/O devices.
6. Use the web interface to configure the following:
  - a. If desired, upload the appropriate IODD files for your IO-Link devices for IO-Link device configuration.
  - b. Use the **Diagnostic** pages to monitor or troubleshoot your devices.

## 2 Hardware Installation

Use the following procedures to install the IO-Link Master hardware:

- *Setting the Rotary Switch (IP67 Model): see chapter 2.1*
- *Connecting to the Network: see chapter 2.2*
- *Connecting the Power: see chapter 2.3*
- *Mounting the IO-Link Master: see chapter 2.3*

**Note:** *The MD 248i-12-8K/L4-2R2K must be installed in a suitable fire, electrical, mechanical enclosure.*

### 2.1 Setting the Rotary Switch (IP67 Model)

You can use the rotary switches under the configuration window on the IO-Link Master to set the lower 3-digits (8 bits) of the static IP address. Optionally, you can leave the rotary switch set to the default and use the embedded web interface to set the network address.

If the rotary switches are set to a non-default position, the upper 9-digits (24 bits) of the IP address are then taken from the static network address. The switches only take effect during startup, but the current position is always shown on **Help | SUPPORT** page.

Using the rotary switches to set the IP address may be useful in the following situations:

- A permanent method to assign IP addresses while setting machines for a special application where a PC or laptop is not available.
- A temporary method to assign IP addresses to several IO-Link Masters so that they do not have duplicate addresses to make setting the IP addresses using software easier. After the web page to change the IP address, reset the rotary switches back to 000.
- An emergency method to return the IO-Link Master back to factory defaults, so that software can be used to program the appropriate IP address, and then return the switches back to 000.

**Note:** *If you set the network address using the rotary switches, the rotary switch setting overrides the network settings in the web interface when the IO-Link Master is initially powered on or after cycling the power.*

Switch Setting	Node Address
000 (Default setting)	Use the network configuration stored in the flash. The default network configuration values are: <ul style="list-style-type: none"> <li>• IP address = 192.168.60.101</li> <li>• Subnet mask = 255.255.255.0</li> <li>• IP gateway = 0.0.0.0</li> </ul> After completing the hardware installation, see chapter 3 Configuring the IO-Link Master with STEP 7 to set the network address using the web interface.
001-254	This is the last three digits in the IP address. This uses the first three numbers from the configured static address, which defaults to 192.168.60.xxx. <b>Note:</b> <i>If software is used to change the IP address to another range before setting the rotary switches, the IO-Link Master uses that IP address range. For example, if the IO-Link Master is set to 10.0.0.250 and the first rotary switch is set to 2, the IP address would be 10.0.0.200.</i>
255-887	Reserved.
888	Reset to factory defaults. If the IO-Link Master is set to 888 and the IP address is changed using other methods, the IP address is returned to the default IP address if the IO-Link Master is rebooted or power cycled.
889-997	Use the network configuration values stored in the flash (reserved).

Switch Setting	Node Address
998	Setting the rotary switches to 998 configures the IO-Link Master to use DHCP addressing.
999	Use the default IP address. If the IO-Link Master is set to 999 and the IP address is changed using other methods, the IP address is returned to the default IP address if the IO-Link Master is rebooted or power cycled.

**2.1.1 MD 748i-11-42/L5-2222 - Setting the Rotary Switch**

Use the following steps if you want to change the default rotary switch settings.

1. Remove the two Phillips screws securing the switch window.
2. Gently swing open the switch window from the left to the right, allowing it to pivot on the hinge on the right side.
3. Turn each dial to the appropriate position using a small flathead screwdriver.

*Note: If you are using the rotary switch to assign a temporary IP address, you may want to leave the door open until you use software to set a permanent IP address. After doing so, you can close and seal the window.*

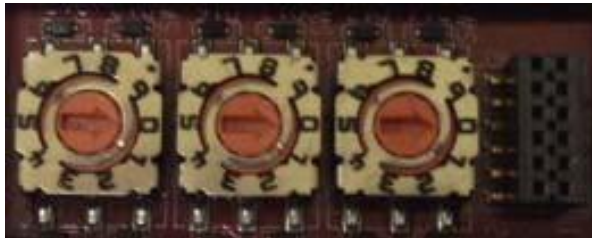

*The default setting is 000 as shown above.  
The arrow points to the switch location. 0 is located at the 3:00*

4. Carefully close the window making sure that it is properly aligned.
5. Reinsert and hand-tighten the two screws making sure that the window is securely sealed.

*Note: Failure to reassemble the configuration window properly may compromise IP67 integrity.*

**2.2 Connecting to the Network**

Use the appropriate procedure for your IO-Link Master model.

**2.2.1 MD 748I-11-42/L5-2222 - Connecting to the Network**

The IO-Link Master provides two Fast Ethernet (10/100BASE-TX), 4-pin female / D-coded M12 connectors.

Pin	Signal
1	Tx+
2	Rx+
3	Tx-
4	Rx-

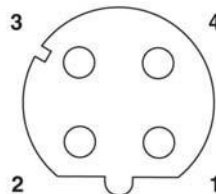

You can use this procedure to connect the IO-Link Master to the network.

1. Securely connect one end of a shielded twisted-pair (Cat 5 or higher) M12 Ethernet cable to either Ethernet port.
2. Connect the other end of the cable to the network.



Power Supply	Values
Power Supply In - Maximum ( $U_S$ )	4A
IO-Link Connectors (Ports 1 - 4) C/Q (Pin 4) $V_S$ (Pins 1 and 3)	200 mA (Maximum) 500 mA (Maximum)
IO-Link Master Power	100mA @ 24VDC ( $V_S$ )
Power Supply Out ( $U_S$ )	4A * (Maximum)
* $U_S$ output available is determined by subtracting the following from the available input current. <ul style="list-style-type: none"> <li>• IO-Link Mode module power</li> <li>• Actual C/Q current for each IO-Link port</li> <li>• Actual <math>V_S</math> current for each IO-Link port</li> </ul>	

You can use this procedure to connect the MD 748i-11-42/L5-2222 to a power supply.

**Note:** Power should be disconnected from the power supply before connecting it to the MD 748i-11-42/L5- 2222. Otherwise, your screwdriver blade can inadvertently short your power supply terminal connections to the grounded enclosure.

1. Securely attach the power cable between the male power connector (**PWR In**) and the power supply.
2. Either attach a power cable between the female power connector and another device to which you want to provide power or securely attach a connector cap to prevent dust or liquids from getting into the connector.
3. Apply the power and verify that the following LEDs are lit indicating that you are ready to attach your IO-Link or digital I/O devices.
  - **PWR** - green lit LED indicates the MD 748i-11-42/L5-2222 is receiving power.
  - **MOD** - this LED is not lit, which indicates there are no errors
  - **NET** - this LED is off unless a PLC is connected. If a PLC is connected, the LED is lit and green.
  - **LINK** should be lit (green) to indicate a valid network connection.
  - **ACT** blinks if there is network traffic between the IO-Link Master and the network.
  - **EIP 1/2** should be lit (green) indicating that the link is up if both connectors are connected.
  - Port LEDs should display in this manner if there is no device attached:



- IO-Link port  LED should be flashing green indicating that it is searching for an IO-Link device.
- **DI** should be off to indicate that there is no device attached to the port.

If the LEDs indicate that you are ready to go to the next installation step:

- Program the IP address using the web interface. Refer to chapter 3 for configuring the network information.
- If using the rotary switches to set the IP address, then you are ready to attach devices using chapter 6.

If the LEDs do not meet the above conditions, you can refer to the IO-Link Master *LEDs* chapter 13, Troubleshooting and Technical Support.

2.3.2 MD 248i-12-8K/L4-2R2K - Connecting the Power

The MD 248i-12-8K/L4-2R2K provides two redundant power inputs with screw terminals on the top and bottom of the unit.

**Note:** Use either power terminal (top or bottom) but **DO NOT** use both to supply power to the IO-Link Master.

Signal	Description
V-	24VDC Power Supply Return
V-	24VDC Power Supply Return
V+	Primary +24VDC Supply
V+	Secondary +24VDC Supply



Power Supply	Values
Power Supply In V+	4A (Maximum) *
IO-Link Connectors Ports 1 - 8 C/Q L+	200 mA (Maximum) 200 mA (Maximum)
Digital IO (D1 and D2   D3 and D4) D2, D4 L+	200 mA (Maximum) 200 mA (Maximum)
IO-Link Master Power	100mA @ 24VDC (V <sub>S</sub> )
Power Supply Out	
* The sum of the following must not exceed V+ maximum input current: <ul style="list-style-type: none"> <li>• IO-Link Mode module power</li> <li>• Actual C/Q current for each IO-Link port and for D2 and D4 output</li> <li>• Actual US current for each IO-Link port</li> </ul>	

You can use this procedure to connect the IO-Link Master to a power supply.

**Note:** Power should be disconnected from the power supply before connecting it to the IO-Link Master. Otherwise, your screwdriver blade can inadvertently short your terminal connections to the grounded enclosure.

1. Insert positive and negative wires (12-24AWG) into the V+ and V- contacts.
 

**Note:** Use either power terminal (top or bottom) but **DO NOT** use both to supply power to the IO-Link Master.
2. Tighten the wire-clamp screws to prevent the wires from coming loose.
3. Apply the power and verify that the following LEDs are lit indicating that you are ready to program the IP address and then attach your IO-Link or digital I/O devices.
  - **PWR** - green lit LED indicates the MD 248i-12-8K/L4-2R2K is receiving power.
  - **MS**, if the LED is off, the IO-Link Master is operating as expected.
  - **NS**, if the NS LED is off; that means that there is no PLC connected. If the LED is lit and green, that means that a PLC is connected.
  - **LINK** should be lit (green) to indicate a valid network connection.
  - **ACT** blinks if there is network traffic between the IO-Link Master and the network.
  - **EIP 1/2** should be lit (green) indicating that the link is up if both connectors are connected.

If the LEDs indicate that you are ready to go to the next installation step:

- Program the IP address using the web interface. Refer to chapter 3 for configuring the network information.
- If using the rotary switches to set the IP address, then you are ready to attach devices using chapter 6.

If the LEDs do not meet the above conditions, you can refer to the IO-Link Master *LEDs* in chapter 13, Troubleshooting and Technical Support.

**2.4 Mounting the IO-Link Master**

Use the appropriate procedure for your IO-Link Master hardware type.

**2.4.1 MD 748i-11-42/L5-2222 - Mounting**

Use the following procedure to mount the IO-Link Master. You can mount the IO-Link Master on a mounting panel or a machine.

1. Verify that the mounting surface is level (flat) to prevent mechanical stress to the IO-Link Master.
2. Attach the IO-Link Master to the surface with two 6mm screws and washers, torque down to 8Nm.

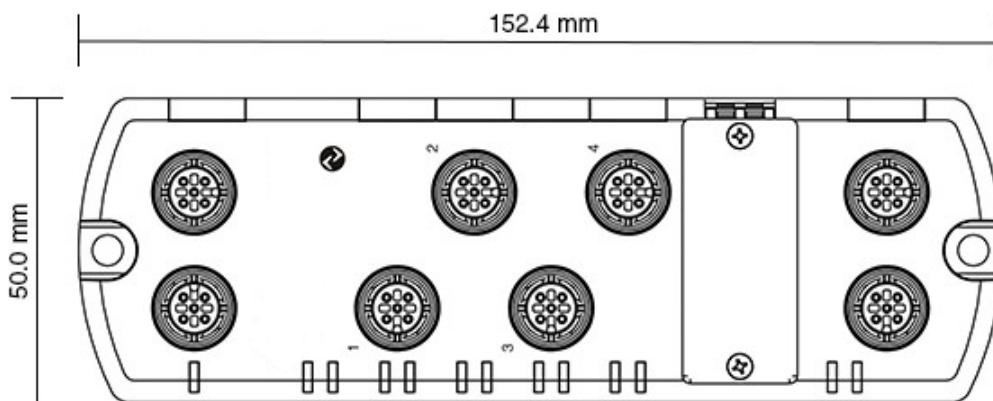

**2.4.2 MD 248i-12-8K/L4-2R2K - Mounting**

You may want to mount the IO-Link Master after programming the IP address and connecting the IO-Link and digital input/output devices.

1. Slide the metal latch down, hook the top of MD 248i-12-8K/L4-2R2K to the DIN rail and release the latch.
2. Verify that is tightly mounted.

**Note:** You may want to connect the IO-Link devices before attaching the MD 248i-12-8K/L4-2R2K to the DIN rail. Use chapter 6 you require IO-Link cabling information.

## 3 Configuring the IO-Link Master with STEP 7

### 3.1 Overview

PROFINET IO configuration procedures vary between software versions but the following configuration steps are required in all cases. Refer to your STEP 7 documentation, if you require step-by-step procedures.

1. Download, unzip, and upload the GSD file for the IO-Link Master.
2. Insert the IO-Link Master in the PROFINET IO system.
3. Configure the IP address for the IO-Link Master.
4. Assign the PROFINET Device Name.
5. Set the IO Device Update Time.
6. Configure the IO-Link ports.
  - a. Configure IO-Link port modules.
  - b. Configure port status modules.
  - c. If desired, configure data storage, automatic or manual - upload or download.
  - d. If desired, configure device validation and data validation.
7. Use chapter 12 PROFINET IO Reference Information to complete configuration after attaching the IO-Link devices.

The following subsections provides PROFINET IO configuration procedures using **STEP 7 V5.5**:

- *Installing the GSD File (STEP 7 V5.5): see chapter 3.1*
- *Configuring the IO-Link Master (STEP 7 V5.5): see chapter 3.2*
- *Assign IP Address: see chapter 3.3*
- *IP Address Assignment: see chapter 3.4*
- *Device Name Assignment: see chapter 3.5*
- *Setting the IO Device Update Time: see chapter 3.6*

### 3.2 Installing the GSD File (STEP 7 V5.5)

Use the following procedure to install the GSD file for PROFINET IO using STEP 7 V5.5.

1. Unzip **GSDML-V2.31-Leuze electronic-IOLink-yyyyymmdd.zip** to a working directory.
2. Open **SIMATIC STEP 7 | HW Config**.
3. Use **Menu Options | Install GSD Files** to install the GSD file.
4. If an older version of the GSD file was installed before, you may need to remove the IO-Link Master object from an existing project, and reinsert it after the new GSDML file is installed.

### 3.3 Configuring the IO-Link Master (STEP 7 V5.5)

Select the IO-Link Master from the Hardware Catalog window and insert it into a PROFINET-IO- System in the **HW Config (PROFINET IO -> Additional Field Device -> Gateway -> Leuze electronic IO-Link Master ->MD 248i-12-8K/L4-2R2K)** as shown in Figure 1.

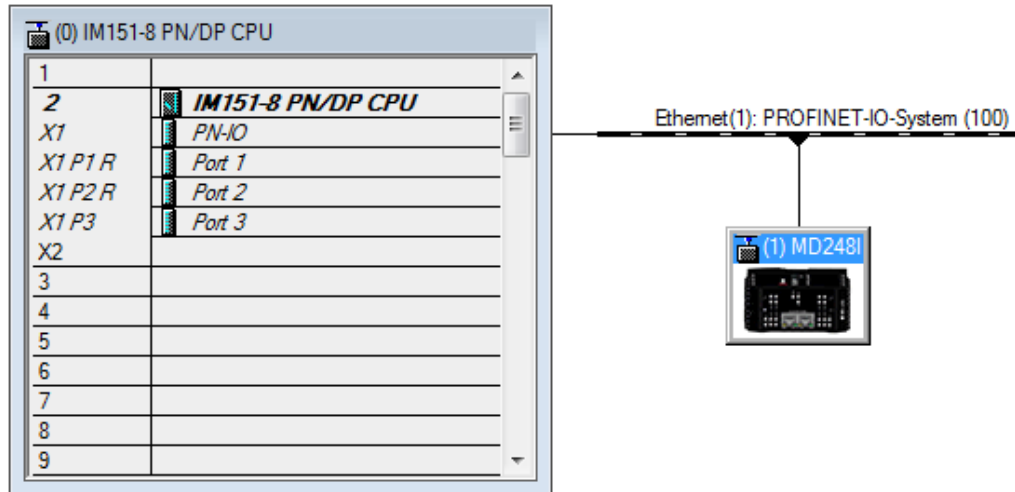

Figure 1: Inserting an MD 248i-12-8K/L4-2R2K into a PROFINET IO System

### 3.4 IP Address Assignment

Leuze electronic IO-Link Master gateways support three methods for IP address assignment according to *GSDHML Specification V2.31*.

- **DCP** - The DAP supports IP address assignment via Discovery and basic Configuration Protocol (DCP). See 3.4.1 Assigning an IP Address via IO Controller (DCP) for procedures.
- **DHCP** - The DAP supports the Dynamic Host Configuration Protocol for IP address assignment. See 3.4.2 Assigning an IP Address via DHCP for procedures.
- **LOCAL** - The DAP supports a device specific method for IP address assignment. See 3.4.3 Assigning an IP Address Statically (LOCAL) for procedures.

#### 3.4.1 Assigning an IP Address via IO Controller (DCP)

An IO controller can assign an IP address to the Leuze electronic IO-Link Master gateway via DCP. The IO controller and the Leuze electronic IO-Link Master gateway have to be on the same subnet. The IO-Link Master default IP address is: 192.168.60.101 and the subnet mask is 255.255.255.0.

1. Double-click the **X1 PNIO-IO** interface of the IO control to open the *Properties* window.
2. On the **General** tab, click the **Properties** button, which opens the *Ethernet interface Properties* window.

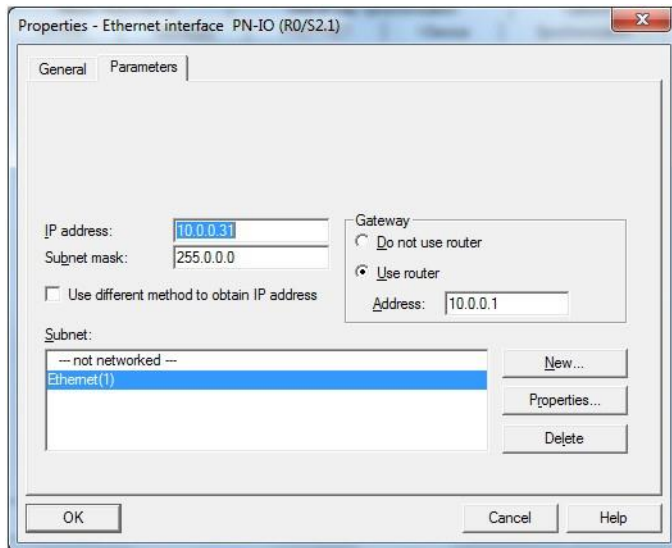

Figure 2: IO Controller Ethernet Interface Properties

3. Uncheck the **Use different method to obtain IP address** option.
4. Manually enter the IP address and subnet mask for the IO controller.  
In this example the IO controller was assigned an IP address of 10.0.0.31 and a subnet mask of 255.0.0.0.
5. Double-click the IO-Link Master; check **Assign IP address via IO controller** as shown in Figure 3.

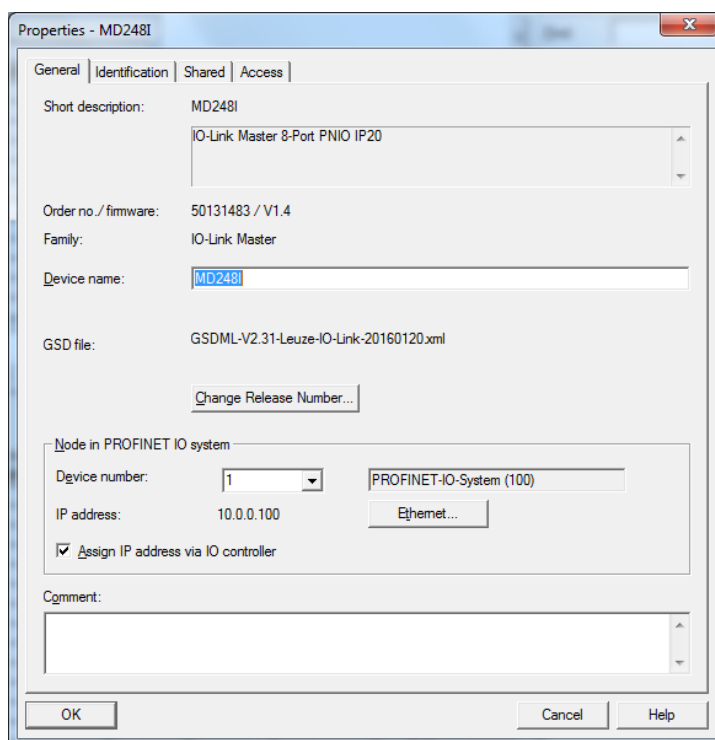

Figure 3: IO-Link Master Properties

6. On the **General** tab, click the **Ethernet** button, which opens the *Ethernet interface properties* window, where you can specify what IP address the IO controller should assign to the IO-Link Master.

Steps 2 through 4 are necessary in STEP 7 V5.5 so that both the IO controller and the IO-Link Master are on the same subnet. Otherwise, the **Assign IP address via IO controller** function may not work correctly. In this example, IP address 10.0.0.100 is assigned to the IO-Link Master via the IO controller.

### 3.4.2 Assigning an IP Address via DHCP

The Leuze electronic IO-Link Master gateway supports DHCP for IP address assignment. DHCP is disabled by default. Use the following steps to enable DHCP.

**Note:** The IO-Link Master default IP address is: 192.168.60.101 and the subnet mask is 255.255.255.0. You may need to change your laptop or PC IP address range to access the IO-Link Master web interface.

1. Open a web browser and enter the IO-Link Master IP address.
2. Click **Configuration | Network**.
3. Click **EDIT** button.

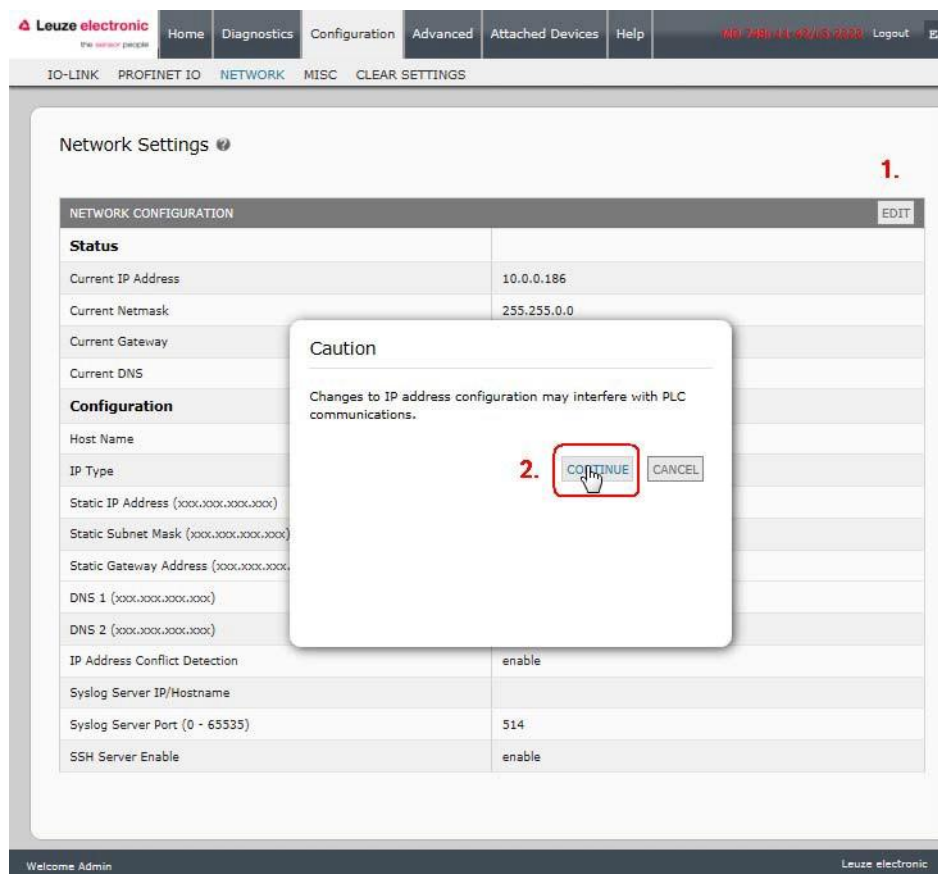

Figure 4: Web Network Configuration Page

4. Change IP Type from **static** to **dhcp**.

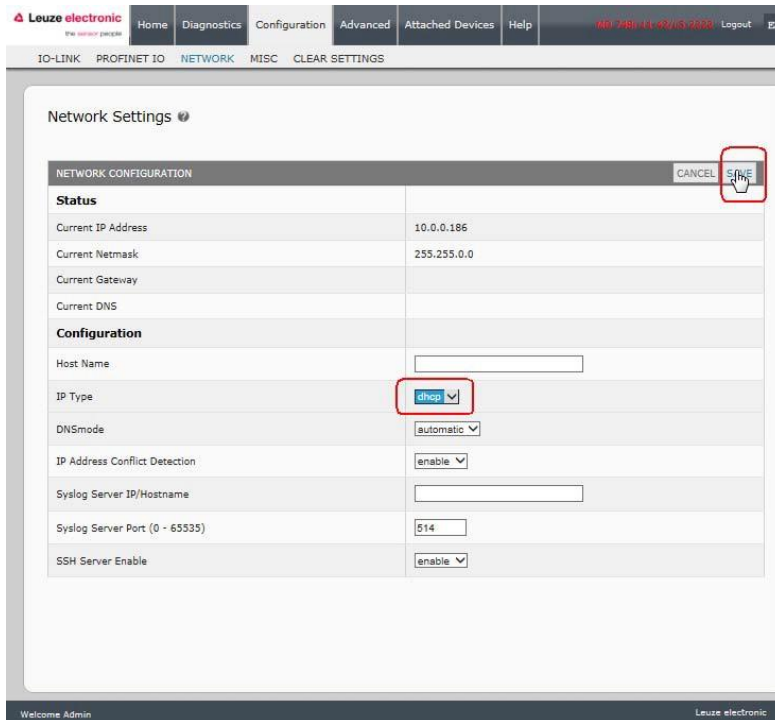

Figure 5: Web Network Configuration Page: DHCP setting

5. Click the **SAVE** button.

Once DHCP is enabled, the IO-Link Master attempts to obtain an IP address from a DHCP server. If a new IP address is assigned by a DHCP server, then the IO-Link Master switches to the new IP address immediately. This may interfere with communications between the device and the IO controller.

The **Obtain IP address from a DHCP server** option in the *Edit Ethernet Node* window in STEP 7 (Figure 7: Configure IP Address and Device Name) is not supported. DHCP can only be enabled or disabled via the web interface.

**Note:** An IO controller can overwrite DHCP IP assignment by assigning IP address via DCP.

The next configuration step is to assign the device name, see 3.5 Device Name Assignment.

### 3.4.3 Assigning an IP Address Statically (LOCAL)

IP addresses can also be assigned statically using one of the following methods:

- The **LOCAL** method as defined in the GSDML Specification
- Embedded web interface

#### 3.4.3.1 Assign IP Address Statically Using STEP 7

Use the following procedure if you want to use the LOCAL method using STEP 7.

1. In the STEP 7 *HW Config* window, double-click the IO-Link Master object to open up the *Properties* window.

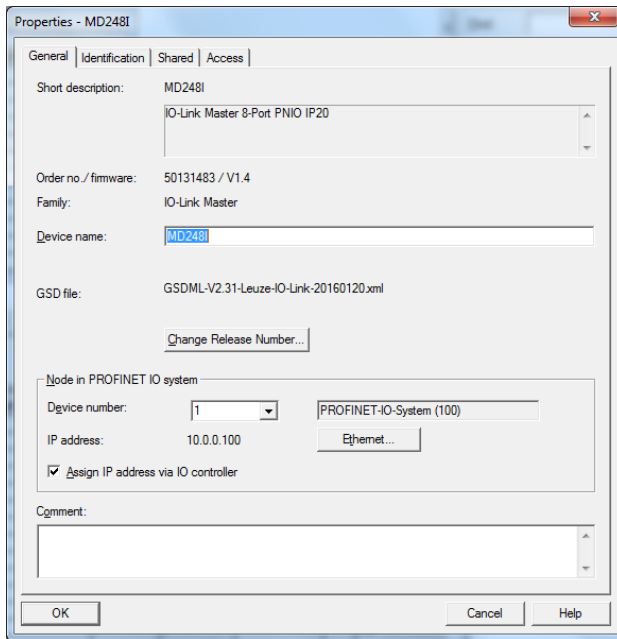

Figure 6: IO-Link Master properties

2. Uncheck the **Assign IP address via IO controller** option and click **OK**.  
The IO controller will not attempt to assign IP address to the IO-Link Master. You must assign a static IP address to the IO-Link Master manually.
3. Select the IO-Link Master in **HW Config**, open the Edit Ethernet Node window (Figure 7: Configure IP Address and Device Name) by using menu **PLC | Ethernet | Edit Ethernet Node** option.
4. Once opened, click the **Browse** button, which opens the *Browse Network* window.  
The IO-Link Master should be displayed as an Leuze electronic IO-Link Master with a default IP address of 192.168.60.101.
5. Select the IO-Link Master and click the **OK** button to return to the *Edit Ethernet Node* window.
6. Enter the desired IP configurations.  
In Figure 7: Configure IP Address and Device Name the IO-Link Master was configured to use a static IP address 10.0.0.100, subnet mask 255.0.0.0 and no router.
7. Click the **Assign IP Configuration** button, the IP configuration is assigned to the IO-Link Master.

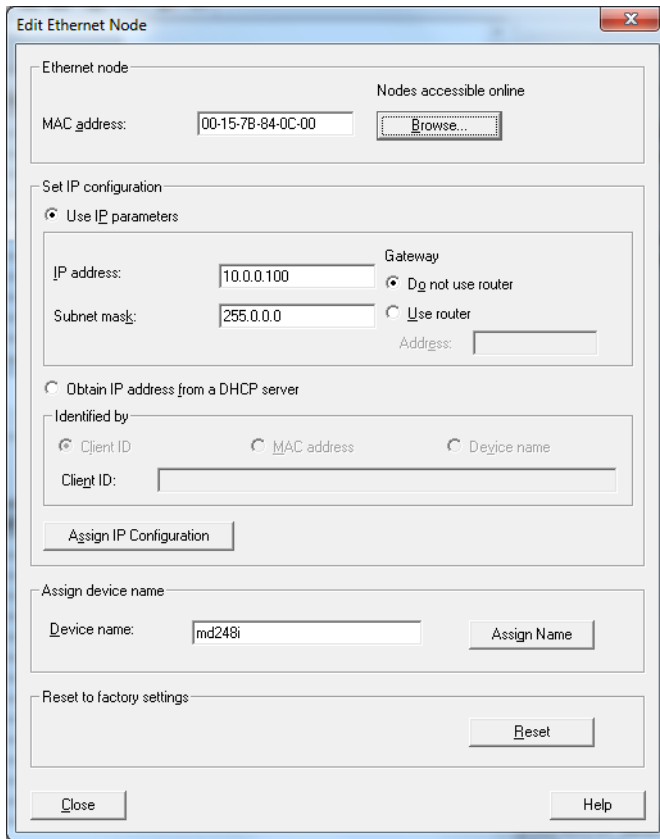

Figure 7: Configure IP Address and Device Name

The next configuration step is to assign the device name, see 3.5 Device Name Assignment.

### 3.4.3.2 Assign IP Address Statically Using the Web Page

You can use the following procedure to configure a static IP address. The IO-Link Master web interface switches to the new IP address immediately.

**Note:** The IO-Link Master default IP address is: 192.168.60.101 and the subnet mask is 255.255.255.0. You may need to change your laptop or PC IP address range to access the IO-Link Master web.

1. Open a web browser and enter the IO-Link Master IP address.
2. Click **Configuration | Network**.

3. Click **EDIT** button.

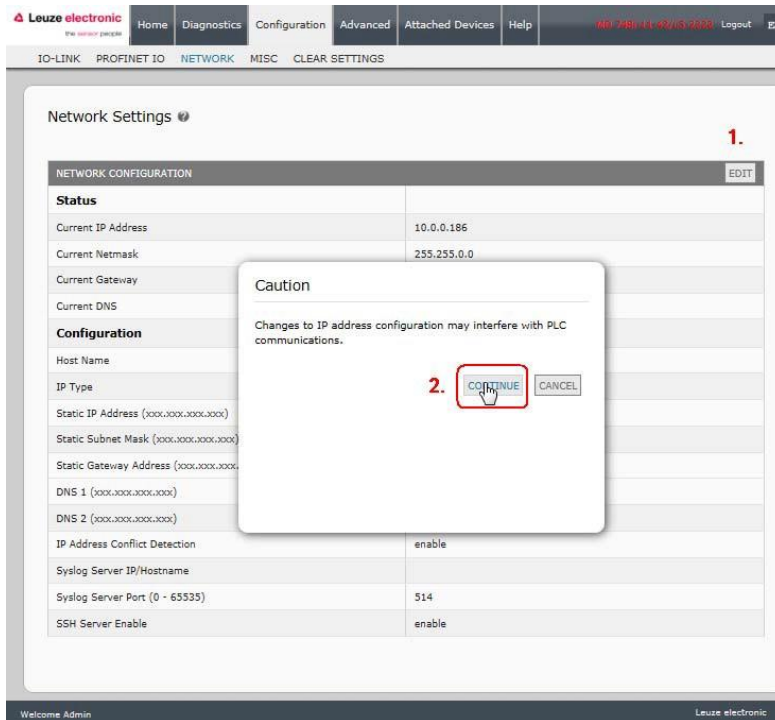

Figure 8: Web Network Configuration Page

4. If necessary, change the **IP Type** to **static**.
5. Enter an IP address, subnet mask, and gateway address.
6. If applicable, enter the DNS1 and DNS2 addresses.

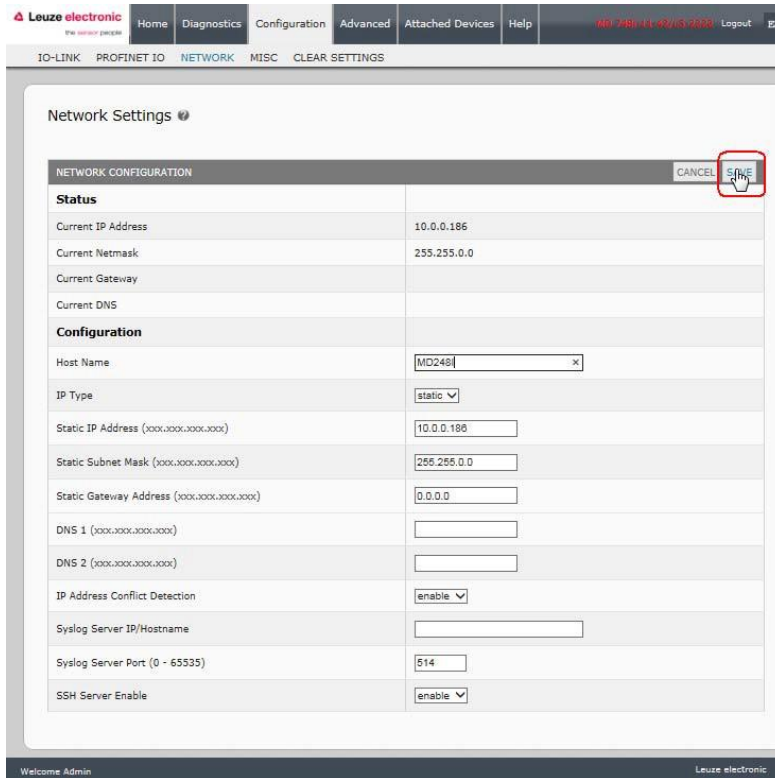

Figure 9: Web Network Configuration Page

7. Click the **SAVE** button.

The next configuration step is to assign the device name, see 3.5 Device Name Assignment.

### 3.5 Device Name Assignment

Use one of the following methods to configure the Device Name.

- STEP 7 - refer to the following procedure
- Web interface - see 3.5.2 Using the Web Interface to Assign the Device Name for information about using the IO-Link Master **Configuration | PROFINET IO** page.

#### 3.5.1 Assign the Device Name in STEP 7

Use the following procedure to configure the Device Name using STEP 7.

1. Select the IO-Link Master, open the Edit Ethernet Node window using the **PLC | Ethernet | Edit Ethernet Node** menu.

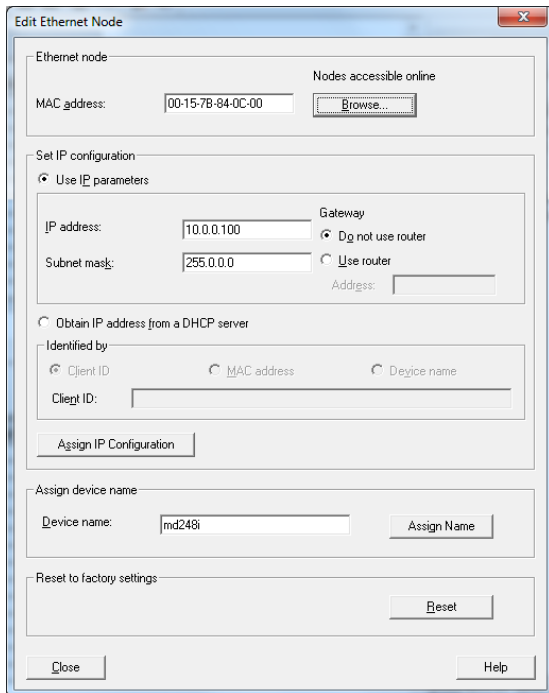

Figure 10: IO-Link Master Ethernet properties

2. Click the **Browse** button to open the Browse Network window. The unit should be displayed as an IO-Link Master with an empty device name.
3. Select the unit and click the **OK** button to return to the *Edit Ethernet Node* window.
4. Set the device name. PROFINET IO Device Names are not case-sensitive. In this example, the device name was set to MD248I.

If there is a cyclic communication between the device and an IO controller, the cyclic communication has to be stopped before the device name can be changed.

### 3.5.2 Using the Web Interface to Assign the Device Name

You can use the **Configuration | Profinet IO Settings** page to assign the device name for PROFINET IO with the IO-Link Master.

**Note:** Changes to device name using the web interface take effect immediately. It may interfere with the communication between the device and IO controller.

1. If necessary, open the IO-Link Master web interface with your web browser using the IP address.
2. Click **Configuration | PROFINET IO Settings**.

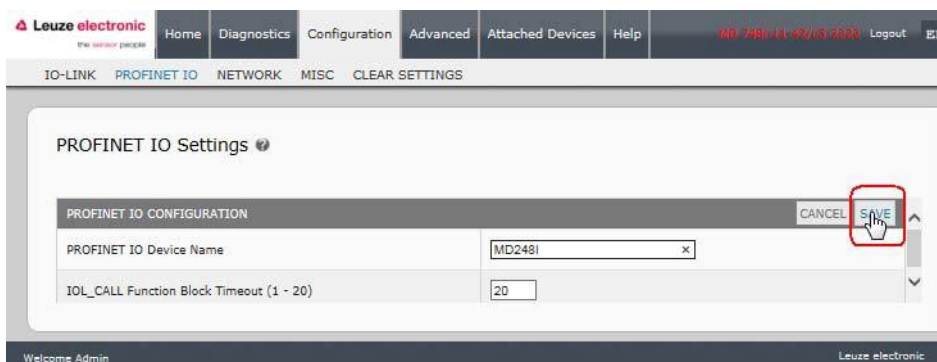

Figure 11: Web configuration PROFINET IO settings

3. Click the **EDIT** button.
4. Enter the **PROFINET IO Device Name**.  
The **PROFINET IO Device Name** is the same as the name later used to configure PROFINET IO for the IO-Link Master. The **PROFINET IO Device Name** is not case-sensitive.
5. If necessary, change the **IOL\_CALL Function Block Timeout** (1-20) value to reflect your environment.
6. Click **SAVE**.

Parameter	Description
PROFINET IO Device Name (Default: empty)	<p>The device name must be specified according to DNS conventions.</p> <ul style="list-style-type: none"> <li>• Restricted to a total of 240 characters (letters, digits, dash or period)</li> <li>• Parts of the name within the device name; in other words, a string between two periods, must not exceed a maximum of 63 characters.</li> <li>• No special characters such as umlauts (ä, ö etc.), brackets, underscore, slash, blank etc. The dash is the only permitted special character.</li> <li>• The device name must not begin or end with the "-" character.</li> <li>• The device name must not begin with numbers.</li> <li>• The device name must not have the structure n.n.n.n (n = 0...999).</li> <li>• The device name must not begin with the character string "port-xyz-" (x, y, z = 0...9).</li> </ul>
IOL_CALL Function Block Timeout (1-20) (Default: 20)	The timeout value in seconds for IOL_CALL function block.

### 3.6 Setting the IO Device Update Time

Use the following procedure to set the IO Device Update Time.

1. Double-click the **Ethernet(1): PROFINET-IO-System (100)**.

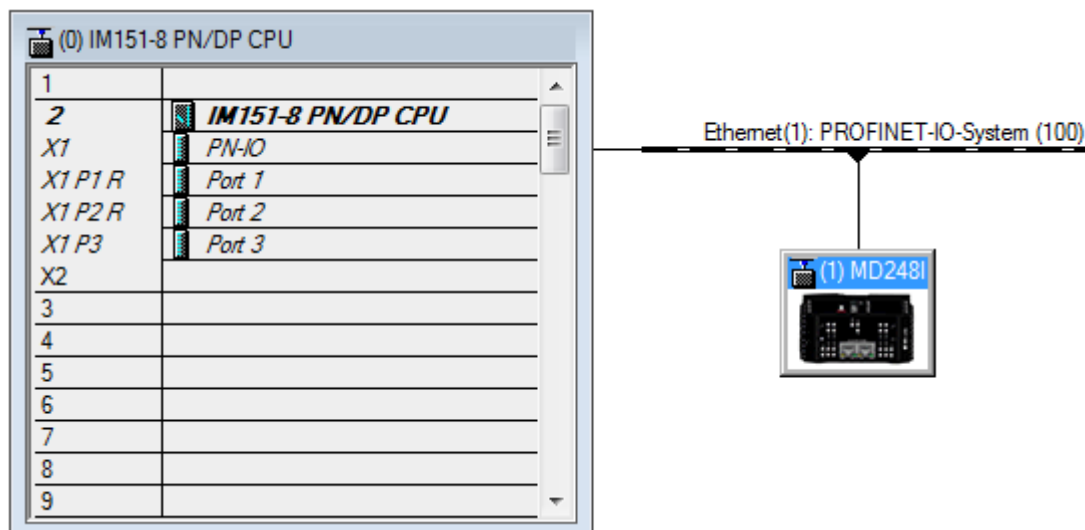

2. In the *Properties - PROFINET IO-System* window, select the **Update Time** tab, as shown in the image below.

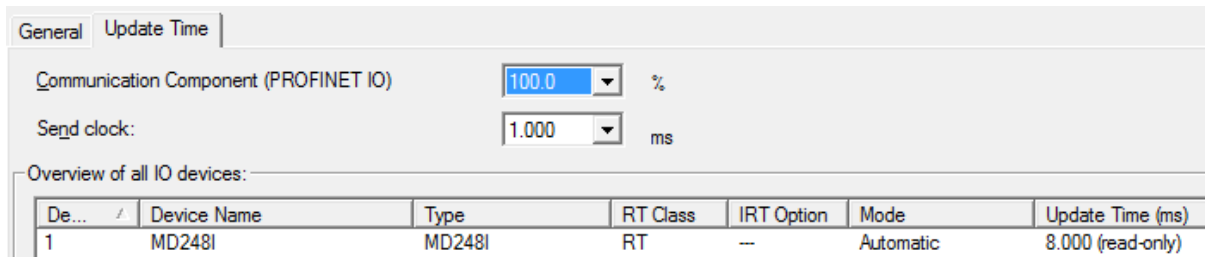

Figure 12: Configuring IO Device Update Timer

3. Set the desired update time. The fastest IO device update time is 8ms.

### 3.7 Configuring IO-Link Ports

The IO-Link Master gateway has two categories of IO modules:

- *IO-Link Port Modules: see chapter 3.7.1*
- *Port Status Modules: see chapter 3.7.2*

IO modules are used to configure IO-Link ports and exchange PDI and PDO data with various IO-Link devices and digital I/O devices. The following image shows available modules of the IO-Link Master.

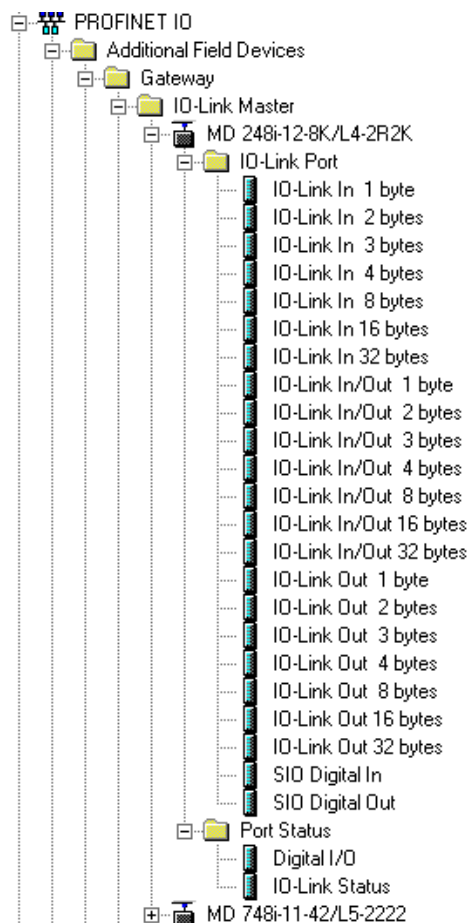

Figure 13: IO-Link Master I/O modules

#### 3.7.1 IO-Link Port Modules

An IO-Link port can be configured as one of the following:

- IO-Link Mode
- SIO Digital In Mode

- SIO Digital Out Mode.

IO-Link Port modules are used to configure the mode of an IO-Link port.

All the IO-Link modules start with the **IO-Link** (that is: IO-Link In, IO-Link Out and IO-Link In/Out) configure the corresponding IO-Link port as IO-Link Mode. An SIO Digital In module configures the IO-Link port as SIO Digital In Mode. Similarly, an SIO Digital Out module configures the port as SIO Digital Out Mode.

- An **IO-Link module** can be input only, output only or both. In addition, there are different modules with various IO data sizes (1 to 32 bytes). For example, the IO-Link In/Out 4 bytes module is for an IO-Link device that supports up to 4-byte PDI data and 4-byte PDO data. If you do not find an exact matching IO size, select the next size (larger). For instance, use IO-Link in 16-bytes module for an IO-Link device that has 10-byte PDI data. The unused PDI data is filled with zeros.
- For **SIO Digital In module**, the PDI data is fixed at 1-byte. A high voltage on the IO-Link port C/Q Pin results in a 0x01 PDI data; a low voltage on the C/Q Pin results in a 0x00 PDI data.
- For **SIO Digital Out module**, the PDO data is fixed at 1-byte. A zero output value from an SIO Digital Out module sets the IO-Link port C/Q pin to low voltage. Any non-zero output value sets the C/Q pin to high voltage.

IO-Link Port Module Input Data Format	
Byte Offset	Description
0	PDI Data Block byte 0
1	PDI Data Block byte 1
...	...
31	PDI Data Block byte 31

IO-Link Port Module Output Data Format	
Byte Offset	Description
0	PDO Data Block byte 0
1	PDO Data Block byte 1
...	...
31	PDO Data Block bytes 31

IO-Link Port modules are allowed in Slot 1 to 4 on the MD 748I-11-42/L5-2222 model, or Slot 1 to 8 on the MD 248i-12-8K/L4-2R2K models. Slot 1 is corresponding to IO-Link Port 1. Slot 2 is for IO-Link Port 2, so on and so forth.

If a slot is unpopulated, the corresponding IO-Link port is not configured. That port uses the previously configured settings, or default settings if it has not been configured before.

### 3.7.1.1 IO-Link Port Settings

Additional IO-Link port settings can be configured by using module parameters.

### 3.7.1.2 IO-Link Port Module Parameters

Use the following information to configure IO-Link port module parameters.

1. Double-click an IO-Link Port module.
2. Select the **Parameters** table. Available parameters are shown in the following figure and the table describes how to use the parameters.

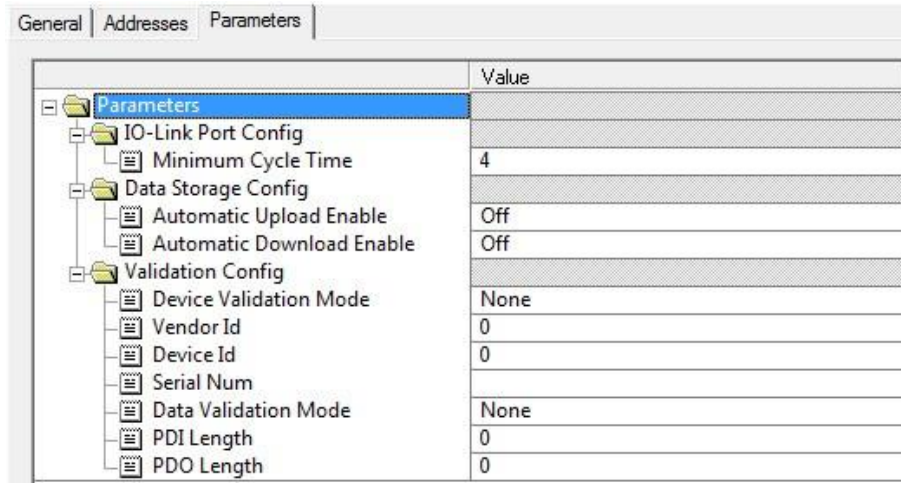

Figure 14: IO-Link Master parameter settings

IO-Link Port Module Parameters	
<b><i>IO-Link Port Config</i></b>	
Minimum Cycle Time (Default: 4) Valid range: 4-538ms	The minimum or fastest cycle time at which the IO-Link device may operate. You can leave the <b>Minimum Cycle Time</b> set to the default value and the IO-Link Master negotiates with the IO-Link device for its minimum cycle time. The IO-Link Diagnostics page displays the <b>Actual Cycle Time</b> , which is the negotiated cycle time.
<b><i>Data Storage Config</i></b>	
Automatic Data Storage Upload Enable <i>Default: Off</i>	<p>When this option is initially set to <b>On</b>, the IO-Link Master saves the data storage (if the data storage is empty) from the IO-Link device to that port. Some IO-Link devices update the data storage contents if you use the Teach buttons on the IO-Link device, but that is determined by the IO-Link device manufacturer.</p> <p>Automatic upload occurs when the <b>Automatic Upload Enable</b> option is set to <b>On</b> and one of these conditions exists:</p> <ul style="list-style-type: none"> <li>• There is no upload data stored on the gateway.</li> <li>• The IO-Link device executes a requests_ at upload function (generally because you have changed the configuration via Teach buttons).</li> </ul> <p>Do not enable both <b>Automatic Upload</b> and <b>Automatic Download</b> at the same time, the results are not reliable among IO-Link device manufacturers.</p> <p>When a port contains data storage for an IO-Link device and if you attach a device whose Vendor and Device ID do not match, the IO-Link LED on the IO-Link Master flashes red to indicate a wrong device is attached. In addition, the IO-Link Diagnostics page displays <b>DV: Wrong Sensor</b> in the <b>IOLink State</b> field.</p> <p>You should not enable <b>Automatic Upload</b> until after you have configured the IO-Link device attached to the port unless you want to capture the default settings. Refer to 10.1 Data Storage for more information.</p>

IO-Link Port Module Parameters	
<b>IO-Link Port Module Parameters</b>	
Automatic Data Storage Download Enable <i>Default: Off</i>	<p>The data stored on the IO-Link Master port is downloaded to the IO-Link device if:</p> <ol style="list-style-type: none"> <li>1. This option is selected.</li> <li>2. The data stored on the IO-Link Master port contains the same Vendor ID and Product ID as the IO-Link device connected to the port.</li> <li>3. The data stored on the IO-Link Master port is different than that of the IO-Link device.</li> <li>4. The IO-Link device requests an upload and the Automatic Upload Enable option is set to Off.</li> </ol> <p>If you change configuration parameters on the IO-Link device and want the parameters to remain loaded on the IO-Link device, you must disable the <b>Automatic Download</b> option because otherwise the IO-Link Master will reload the data storage on the port down to the IO-Link device.</p> <p>Do not enable both <b>Automatic Upload</b> and <b>Automatic Download</b> at the same time, the results are not reliable among IO-Link device manufacturers.</p>
<b>Validation Config</b>	
Device Validation Mode (Default: None)	<p><b>Device Validation Mode</b> provides these options:</p> <ul style="list-style-type: none"> <li>• <b>None</b> - this disables Device Validation Mode.</li> <li>• <b>Compatible</b> - permits a compatible IO-Link device (same Vendor ID and Device ID) to function on the corresponding port.</li> <li>• <b>Identical</b> - only permits an IO-Link device to function on the corresponding port as defined in the following fields. <ul style="list-style-type: none"> <li>• <b>Vendor ID</b></li> <li>• <b>Device ID</b></li> <li>• <b>Serial Number</b></li> </ul> </li> </ul>
Vendor Id (0-65535)	This is required if you select a <b>Device Validation Mode</b> other than <b>None</b> .
Device Id (0-16777215)	This is required if you select a <b>Device Validation Mode</b> other than <b>None</b> .
Serial Num	This is required if you select <b>Identical</b> for the <b>Device Validation Mode</b> .
Data Validation Mode (Default: None)	<p>There are three <b>Data Validation Modes</b>:</p> <ul style="list-style-type: none"> <li>• <b>None</b> - no data validation is performed on the port.</li> <li>• <b>Loose</b> - the slave device's PDI/PDO lengths must be less than or equal to the user-configured values.</li> <li>• <b>Strict</b> - the slave device's PDI/PDO lengths must be the same as the user-configured values.</li> </ul>
PDI Length (0-32)	<p>This is input length of the PDI data field.</p> <p>This is required if you select a <b>Data Validation Mode</b> other than <b>None</b>.</p>
PDO Length (0-32)	<p>This is input length of the PDO data field.</p> <p>This is required if you select a <b>Data Validation Mode</b> other than <b>None</b>.</p>

### 3.7.1.3 SIO Digital In/Out Module Parameters

Use the following procedure to configure SIO digital in/out module parameters.

1. Double-click an SIO Digital In or SIO Digital Output module.
2. Select the **Parameters** table. Available parameters are shown in the next two images and the table describes SIO digital input and output module parameters.

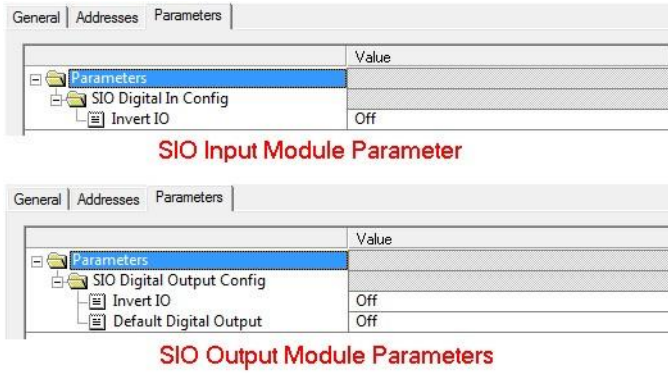

Figure 15: IO-Link Master I/O settings

SIO Digital Input and Output Module Parameters	Description
<b><i>SIO Digital Input</i></b>	
Invert IO (Default: False)	If enabled, this inverts the I/O value. <ul style="list-style-type: none"> <li>• <b>False</b> (Disabled - Do not invert IO)</li> <li>• <b>True</b> (Enabled - Invert IO)</li> </ul> <i>Note: This does not affect the Auxiliary Input.</i>
<b><i>SIO Digital Output</i></b>	
Invert IO (Default: False)	If enabled, this inverts the I/O value. <ul style="list-style-type: none"> <li>• <b>False</b> (Disabled - Do not invert IO)</li> <li>• <b>True</b> (Enabled - Invert IO)</li> </ul> <i>Note: This does not affect the Auxiliary Input.</i>
Default Digital Output (Default: Off)	Defines the default digital output value that is used at startup and when there is no active PDO controller. <ul style="list-style-type: none"> <li>• <b>Off</b> (low voltage)</li> <li>• <b>On</b> (high voltage)</li> </ul>

### 3.7.2 Port Status Modules

There are two **Port Status** modules:

- IO-Link Status Module
- Digital I/O Module.

#### 3.7.2.1 IO-Link Status Module

IO-Link Status module is a 4-byte input only module that provides status information of all IO-Link ports. The following table shows the data format of IO-Link Status module.

Byte Offset	Status Byte Description
0	IO-Link Active
1	IO-Link PDI Valid
2	IO-Link Auxiliary Input
3	IO-Link Error

Each IO-Link port is mapped into one bit of each byte in the IO-Link Status module as shown in this table. For IO-Link Active status byte (offset 0), a bit one means the corresponding IO-Link port is active. An IO-Link port is considered as active when it is configured correctly and has a working IO-Link device

attached.

A bit one in IO-Link PDI Valid status byte (offset 1) means the PDI data from the corresponding IO-Link port is valid. PDI Valid is only applicable to IO-Link port modules that have input data.

- If there are any errors detected when communicating with the IO-Link device, the corresponding bit in the IO-Link Error status byte (offset 2) will be set to 1.
- If a high voltage is detected on the auxiliary input of an IO-Link port, the corresponding bit in the IO-Link Auxiliary Input status byte (offset 3) will be set to 1.

See the following table for the description of each byte of the **IO-Link Status** module.

Status Byte	Status Bit Description
IO-Link Active	<ul style="list-style-type: none"> <li>• 0: IO-Link port is not active, no IO-Link device is detected.</li> <li>• 1: IO-Link port is active, an IO-Link device is detected and operational.</li> </ul>
IO-Link PDI Valid	<ul style="list-style-type: none"> <li>• 0: IO-Link port PDI data is not valid.</li> <li>• 1: IO-Link port PDI data is valid.</li> </ul>
IO-Link Auxiliary Input	<ul style="list-style-type: none"> <li>• 0: Low voltage detected on the auxiliary pin of an IO-Link port.</li> <li>• 1: High voltage detected on the auxiliary pin of an IO-Link port.</li> </ul>
IO-Link Error	<ul style="list-style-type: none"> <li>• 0: No error detected</li> <li>• 1: An error detected. The further information about the error is available in PROFINET IO channel diagnostics.</li> </ul>

### 3.7.2.2 Digital I/O Module

Digital I/O module has 1-byte input and 1-byte output. There are a total of four digital I/O ports: DIO 1-4 on applicable models (MD 248i-12-8K/L4-2R2K).

DIO 2 and DIO 4 can be configured as outputs. Use the following table to map DIO pins into bits of Digital IO module.

For input, a bit one means that high voltage is detected on that DIO pin. A zero means low voltage is detected on the DIO pin. Bits 4-7 are not in use and always return as zeros.

Digital I/O Module Bit Map								
	Bit 7	Bit 6	Bit 5	Bit 4	Bit 3	Bit 2	Bit 1	Bit 0
DIO Input	0	0	0	0	DIO 4	DIO 3	DIO 2	DIO 1
DIO Output	-	-	-	-	DIO 4	-	DIO 2	-

To use DIO 2 and DIO 4 as outputs, first they need to be configured as digital output. Use the following procedure to configure digital output.

1. Double-click the **Digital I/O** module to open up the *Parameters* window, as shown in the following figure.
2. Change the parameter **Mode** of DIO 2 and DIO 4 to **Digital Output**.  
Once configured, writing a one to Bit 1 and Bit 3 of the Digital I/O module output sets DIO 2 and DIO 4 pins to high. Clearing Bit 1 and Bit 3 to zero sets DIO 2 and DIO 4 pins to low.

**Note:** Only Bit 1 and Bit 3 of the Digital I/O module output are in use. Changing the value of other bits has no effects.

The following table shows the description of available parameters of Digital I/O Module.

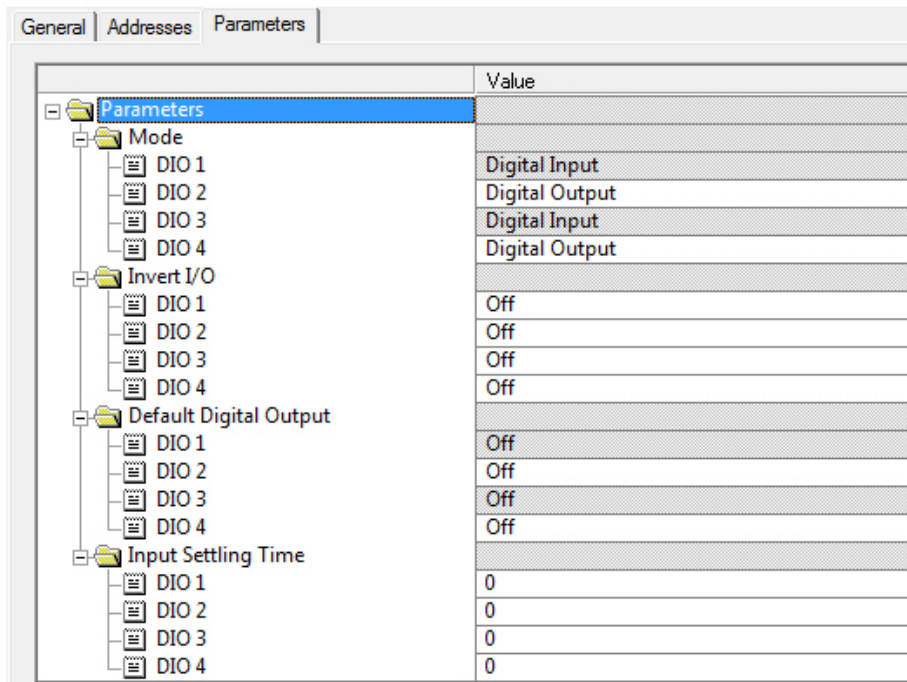

Figure 16: Digital I/O settings

Digital I/O Module Parameters	Description
Mode (Default: Digital Input)	<ul style="list-style-type: none"> <li><b>Digital Input</b> - monitors the digital input status on the DIO terminal screw connection</li> <li><b>Digital Output</b> - sets the digital output to either the default setting or value received from a controller.</li> </ul>
Invert I/O (Default: Off)	If enabled, this inverts the I/O value. If <b>Mode</b> is set to <b>Digital Input</b> , this inverts the input status. If <b>Mode</b> is set to <b>Digital Output</b> , this inverts both input and output. <ul style="list-style-type: none"> <li><b>False</b> (Disabled - Do not invert IO)</li> <li><b>True</b> (Enabled - Invert IO)</li> </ul>
Default Digital Output (Default: Off)	Defines the default digital output value at startup before a controller can set the digital output, or when communication to all controller(s) has been lost. <ul style="list-style-type: none"> <li><b>Off</b> (low voltage)</li> <li><b>On</b> (high voltage)</li> </ul>
Input Settling Time 0-10000ms (Default: 0ms)	If non-zero and <b>Mode</b> is set to <b>Digital Input</b> , the required time that the input status must remain constant before an input status change is reported.

### 3.7.3 Configuring IO-Link Ports with the Web Interface

IO-Link port settings (for example, port mode, minimum cycle time, data storage, validation, and device validation) should be configured through STEP 7 by adding correct modules and setting modules' parameters. Optionally, the same settings can be changed through the web interface.

**Note:** Any changes made through the web interface are overwritten when an application relation is established between a gateway and an IO controller.

This page provides special features such as Data Storage, Device Validation, and Data Validation.

**Note:** Do not configure Data Storage until the IO-Link device is configured. Data Storage, Device Validation, and Data Validation are discussed in chapter 10 Utilizing IO-Link Master Features.

You can use this procedure to configure IO-Link settings for each IO-Link port.

If an IO-Link device is attached to the port, no configuration is required for operation. If a digital input or output device is attached, it is necessary to change the **Port Mode**.

1. If necessary, open the IO-Link Master web interface with your web browser using the IP address.
2. Click **Configuration | IO-Link Settings**.
3. Click the **EDIT** button for the port or ports that you want to configure.

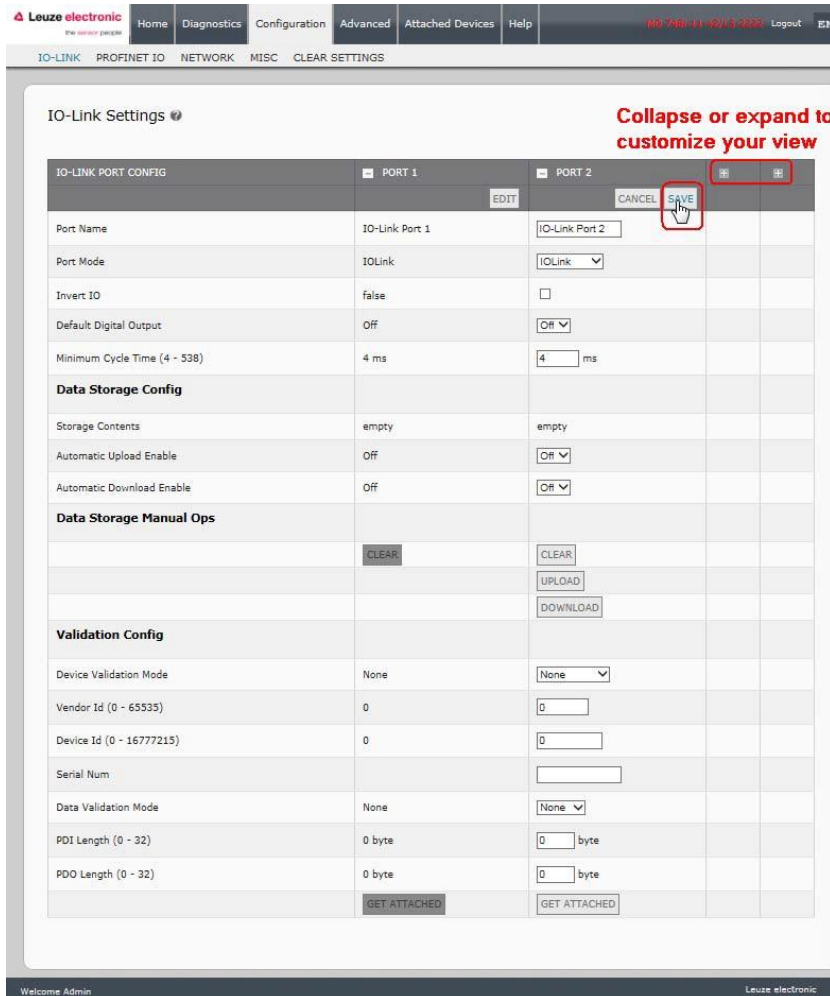

Figure 17: Web configuration IO\_Link interface

**Note:** You can click each **EDIT** button and open all ports to quickly configure port parameters.

4. Make appropriate selections for the device that you connected to that port.

Make sure you select the **DigitalIn** option for a digital input device and the **DigitalOut** option for a digital output device for the **Port Mode**.

The IO-Link Master negotiates the **Minimum Cycle Time** so it is not necessary to set a cycle time unless you need a specific cycle time.

You can use the help system if you require definitions or values for the options or refer to the following table.

**Note:** Do not configure Data Storage until the IO-Link device is configured.

**Note:** Do not enable **Automatic Download** and then attempt device configuration as Automatic Download changes the settings back to what is stored on the IO-Link Master. Data Storage, Device Validation, and Data Validation are discussed in 10 Utilizing IO-Link Master Features.

5. Click the **SAVE** button for each port.
6. Return to the **IO-Link Diagnostics** page to verify that your changes have taken affect. The **Configuration | IO-Link Settings** page supports the following options.

<b>IO-LINK Settings Page</b>	
Port Name	User defined port or device description. <ul style="list-style-type: none"> <li>• Standard ASCII characters</li> <li>• Max length = 80 characters</li> </ul>
Port Mode <i>Default:</i> IO-Link	Selected IO-Link port mode. Valid settings are: <ul style="list-style-type: none"> <li>• <b>Reset</b> - Select to disable a port or to reset/restart an IO-Link port.</li> <li>• <b>IO-Link</b> - Select to connect and operate an IO-Link device on the port.</li> <li>• <b>Digital In</b> - Select if a DI device is attached to the port.</li> <li>• <b>Digital Out</b> - Select if a DO device is attached to the port.</li> </ul>
Invert IO <i>Default:</i> False	If enabled and the <b>Port Mode</b> is <b>Digital In</b> or <b>Digital Out</b> , this option inverts the I/O value. <ul style="list-style-type: none"> <li>• <b>False</b> (Disabled - Do not invert IO)</li> <li>• <b>True</b> (Enabled - Invert IO)</li> </ul> <p><i>Note: This option does not affect the Auxiliary Input.</i></p>
Default Digital Output <i>Default:</i> Off	If the port mode is <b>Digital Out</b> , defines the default digital output value that is used at startup and when there is no active PDO controller. <ul style="list-style-type: none"> <li>• <b>Off</b> (low voltage) - 0</li> <li>• <b>On</b> (high voltage) - 24V</li> </ul>
Minimum Cycle Time <i>Default:</i> 4	The minimum, or fastest, cycle time at which the IO-Link device may operate. The valid range is 4-538 ms. You can leave the <b>Minimum Cycle Time</b> set to the default value and the IO-Link Master negotiates with the IO-Link device for its minimum cycle time. The <b>IO-Link Diagnostics</b> page displays the <b>Actual Cycle Time</b> , which is the negotiated cycle time.
<b>Data Storage Config</b>	
Storage Contents	Indicates that the data storage for the port is <b>empty</b> or displays the Vendor ID and Product ID of the data stored on that port.
Automatic Data Storage Upload Enable <i>Default:</i> Off	When this option is initially set to <b>On</b> , the IO-Link Master saves the data storage (if the data storage is empty) from the IO-Link device to that port. Some IO-Link devices update the data storage contents if you use the Teach buttons on the IO-Link device, but that is determined by the IO-Link device manufacturer. Automatic upload occurs when the <b>Automatic Upload Enable</b> option is set to <b>On</b> and one of these conditions exists: <ul style="list-style-type: none"> <li>• There is no upload data stored on the gateway.</li> <li>• The IO-Link device executes a requests_ at upload function (generally because you have changed the configuration via Teach buttons).</li> </ul> Do not enable both <b>Automatic Upload</b> and <b>Automatic Download</b> at the same time, the results are not reliable among IO-Link device manufacturers. When a port contains data storage for an IO-Link device and if you attach a device whose Vendor and Device ID do not match, the IO-Link LED on the IO-Link Master flashes red to indicate a wrong device is attached. In addition, the IO-Link Diagnostics page displays <b>DV: Wrong Sensor</b> in the <b>IOLink State</b> field. You should not enable Automatic Upload until after you have configured the IO-Link device attached to the port unless you want to capture the default settings. Refer to Data Storage for more information.

<b>IO-LINK Settings Page</b>	
<p>Automatic Data Storage Download Enable <i>Default: Off</i></p>	<p>The data stored on the IO-Link Master port is downloaded to the IO-Link device if:</p> <ol style="list-style-type: none"> <li>1. This option is selected.</li> <li>2. The data stored on the IO-Link Master port contains the same Vendor ID and Product ID as the IO-Link device connected to the port.</li> <li>3. The data stored on the IO-Link Master port is different than that of the IO-Link device.</li> <li>4. The IO-Link device requests an upload and the Automatic Upload Enable option is set to Off.</li> </ol> <p>If you change configuration parameters on the IO-Link device and want the parameters to remain loaded on the IO-Link device, you must disable the <b>Automatic Download</b> option because otherwise the IO-Link Master will reload the data storage on the port down to the IO-Link device.</p> <p>Do not enable both <b>Automatic Upload</b> and <b>Automatic Download</b> at the same time, the results are not reliable among IO-Link device manufacturers.</p>
<p>Data Storage Manual Ops</p>	<p>The <b>Manual Data Storage Ops</b> option provides the following functionality, if data storage is supported by the IO-Link device.</p> <ul style="list-style-type: none"> <li>• <b>CLEAR</b> - this clears any stored data for an IO-Link device on this port.</li> <li>• <b>UPLOAD</b> - this uploads and stores the IO-Link device configuration on the IO-Link Master.</li> <li>• <b>DOWNLOAD</b> - this downloads the stored IO-Link device configuration from the IO-Link Master to the IO-Link device attached to this port if the Vendor ID and Device ID match.</li> </ul>
<b>Validation Config</b>	
<p>Device Validation Mode <i>(Default: None)</i></p>	<p><b>Device Validation Mode</b> provides these options:</p> <ul style="list-style-type: none"> <li>• <b>None</b> - this disables <b>Device Validation Mode</b>.</li> <li>• <b>Compatible</b> - permits a compatible IO-Link device (same Vendor ID and Device ID) to function on the corresponding port.</li> <li>• <b>Identical</b> - only permits an IO-Link device to function on the corresponding port as defined in the following fields. <ul style="list-style-type: none"> <li>• Vendor ID</li> <li>• Device ID</li> <li>• Serial Number</li> </ul> </li> </ul>
<p>Vendor Id (0-65535)</p>	<p>This is required if you select a <b>Device Validation Mode</b> other than <i>None</i>. The <b>Vendor ID</b> can be manually entered in this field or click the <b>GET ATTACHED</b> button and the IO-Link Master propagates the <b>Vendor ID</b> in this field.</p>
<p>Device Id (0-16777215)</p>	<p>This is required if you select a <b>Device Validation Mode</b> other than <i>None</i>. The <b>Device ID</b> can be manually entered in this field or click the <b>GET ATTACHED</b> button and the IO-Link Master propagates the <b>Device ID</b> in this field.</p>
<p>Serial Num</p>	<p>This is required if you select <b>Identical</b> for the <b>Device Validation Mode</b>. The <b>Serial Number</b> can be manually entered in this field or click the <b>GET ATTACHED</b> button and the IO-Link Master propagates the serial number in this field.</p>
<p>Data Validation Mode <i>(Default: None)</i></p>	<p>There are three <b>Data Validation Modes</b>:</p> <ul style="list-style-type: none"> <li>• <b>None</b> - no data validation is performed on the port.</li> <li>• <b>Loose</b> - the slave device's PDI/PDO lengths must be less than or equal to the user-configured values.</li> <li>• <b>Strict</b> - the slave device's PDI/PDO lengths must be the same as the user-configured values.</li> </ul>

<b>IO-LINK Settings Page</b>	
PDI Length (0-32)	<p>This is input length of the PDI data field.</p> <p>This is required if you select a <b>Data Validation Mode</b> other than <i>None</i>.</p> <p>The <b>PDI Length</b> can be manually entered in this field or click the <b>GET ATTACHED</b> button and the IO-Link Master propagates the PDI length in this field.</p>
PDO Length (0-32)	<p>This is input length of the PDO data field.</p> <p>This is required if you select a <b>Data Validation Mode</b> other than <i>None</i>.</p> <p>The <b>PDO Length</b> can be manually entered in this field or click the <b>GET ATTACHED</b> button and the IO-Link Master propagates the PDO length in this field.</p>
GET ATTACHED (Button)	<p>After opening a port for editing, you can click the <b>GET ATTACHED</b> button instead of manually entering data in the following fields:</p> <ul style="list-style-type: none"> <li>• Vendor Id</li> <li>• Device Id</li> <li>• Serial Num</li> <li>• PDI Length</li> <li>• PDO Length</li> </ul>

## 4 IO-Link Master Device Configuration

The following topics are discussed in this chapter.

- 4.1 *Setting User Accounts and Passwords*
- 4.2 *Configuring Miscellaneous Settings*

### 4.1 Setting User Accounts and Passwords

The IO-Link Master is shipped from the factory without passwords. Refer to the following table if you want to see how permissions are granted.

Page	Admin	Operator	User
Log-in	Yes	Yes	Yes
Home	Yes	Yes	Yes
Diagnostics - All	Yes	Yes	Yes
Configuration - IO-Link Settings	Yes	Yes	View-only
Configuration - Digital I/O Settings (Applicable models)	Yes	Yes	View-only
Configuration - PROFINET IO	Yes	Yes	View-only
Configuration - Network	Yes	View-only	No
Configuration - Misc	Yes	Yes	Yes
Configuration - Clear Settings	Yes	No	No
Advanced - Software	Yes	No	No
Advanced - Accounts	Yes	No	No
Advanced - Log Files	Yes	Yes	Yes
Advanced - Licenses	Yes	Yes	Yes
Attached Devices - IO-Link Device Description Files	Yes	Yes	View-only
Attached Devices - IO-Link Device Configuration Summary	Yes	Yes	View-only
Attached Devices - IO-Link Device - Port	Yes	Yes	View-only

You can use this procedure to set up passwords for the IO-Link Master.

1. Open your browser and enter the IO-Link Master IP address.
2. Click **Advanced | ACCOUNTS**.

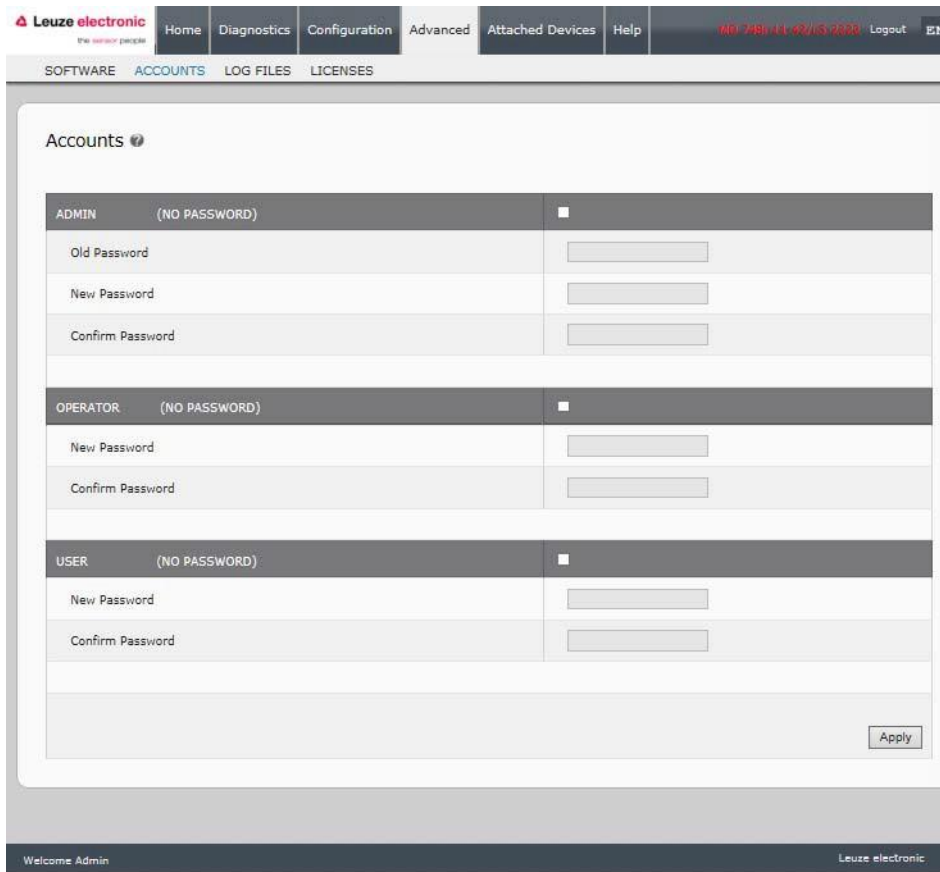

Figure 18: Setting user accounts

3. Click the **ADMIN** check box.
4. If applicable, enter the old password in the **Old Password** text box.
5. Enter the new password in the **New Password** text box.
6. Re-enter the password in the **Confirm Password** text box.
7. Optionally, click the **Operator** check box, enter a new password, and re-enter the password in the **Confirm Password** text box.
8. Optionally, click the **User** check box, enter the new password, and re-enter the password in the **Confirm Password** text box.
9. Click **Apply**.
10. Close the new window that displays a *Password saved* banner.

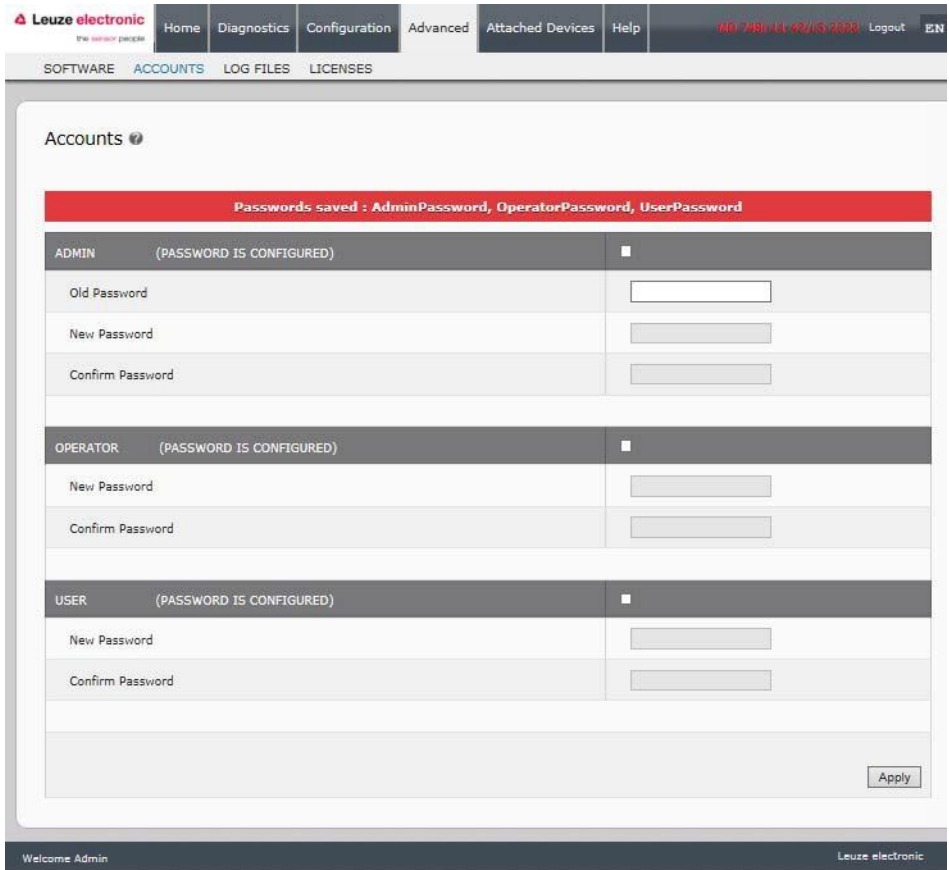

Figure 19: Setting user account passwords

11. Click the **Log out** button on the top navigation bar.
12. Re-open the web interface by selecting the appropriate user type in the drop list and entering the password.

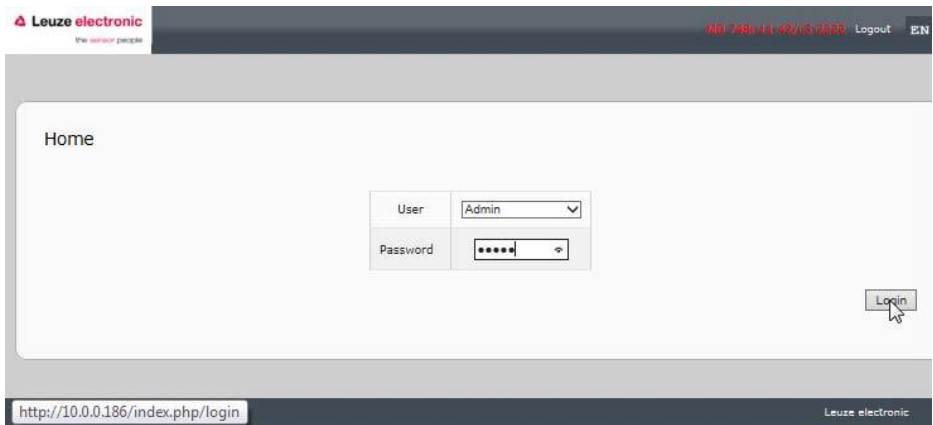

Figure 20: User account login

#### 4.2 Configuring Miscellaneous Settings

The **Miscellaneous Settings** page includes these options:

- **Menu Bar Hover Shows Submenu**  
This option displays sub-menus for a category when you hover over the category name. For example, if you hover over **Advanced**, the **SOFTWARE**, **ACCOUNTS**, **LOG FILES**, and **LICENSES** sub- menus display. You can click any submenu and avoid opening the default menu for a category.

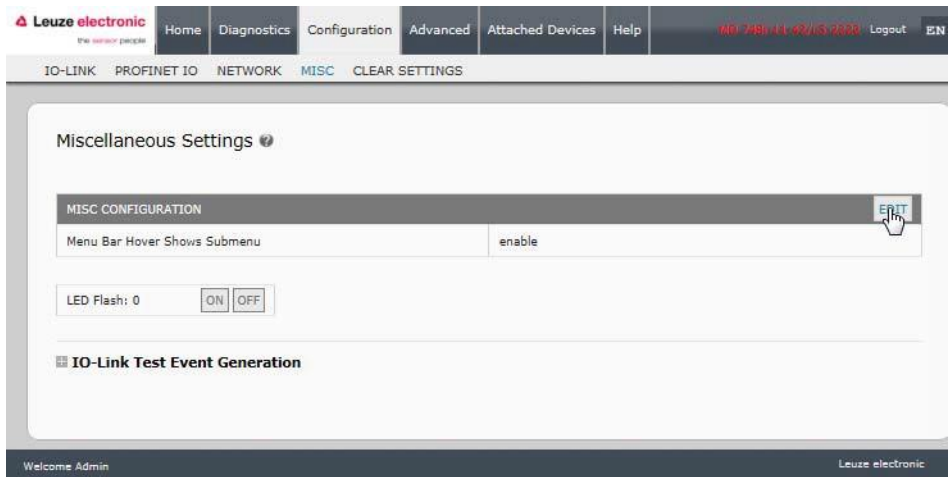

Figure 21: Miscellaneous settings: LED flash

- **LED Flash**  
 You can force the IO-Link port LEDs on the IO-Link Master into a flashing tracker pattern that allows you to easily identify a particular unit.
  - Click the **ON** button to enable the LED tracker feature on the IO-Link Master. The LEDs remain flashing until you disable the LED tracker feature
  - Click the **OFF** button to disable the LED tracker.

## 5 Updating Images and Applications

This chapter provides an overview of the software (images and applications) on the IO-Link Master. In addition it contains procedures to update images and application subassemblies.

### 5.1 Images and Application Subassemblies Overview

The IO-Link Master is loaded with the latest images at the factory but you may need to update images or application subassemblies to have access to the latest features.

You can view all image and application versions in the IO-Link Master **ADVANCED | Software** page.

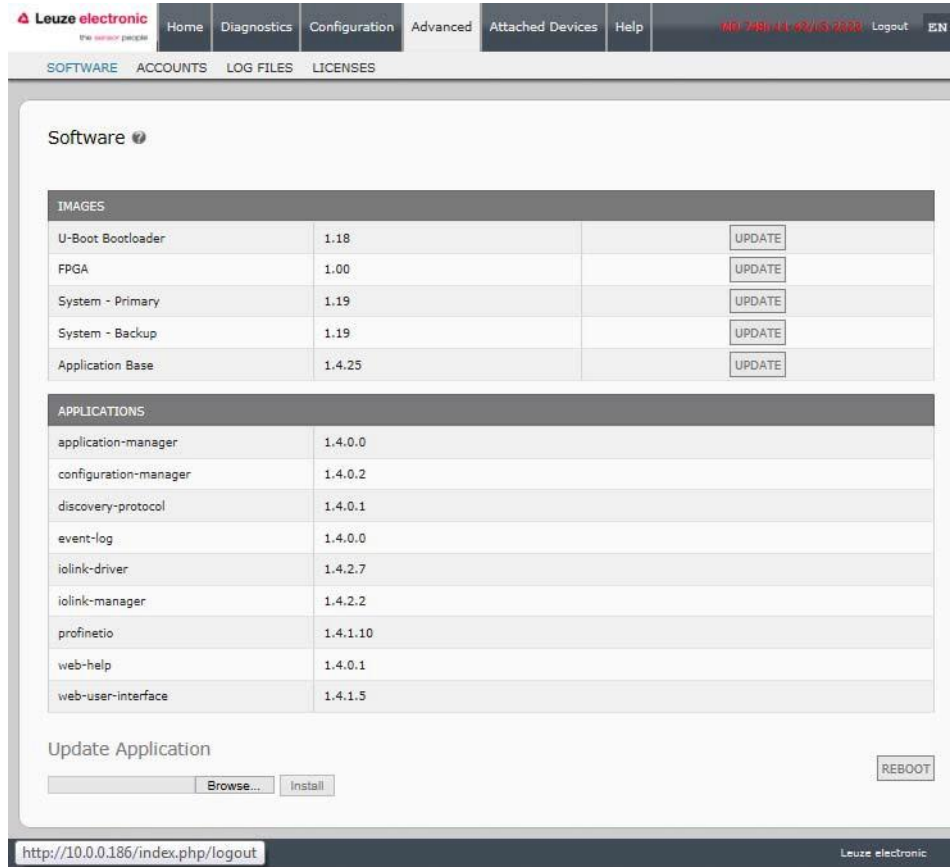

Figure 22: IO-Link master software update

#### 5.1.1 Images

The following table discusses IO-Link Master images.

IO-Link Master Images	
U-Boot Bootloader	U-Boot is a high-level Bootloader that has networking and console command line capabilities. Among other things, it implements a TFTP server and Leuze electronic Corporation's new discovery protocol. This verifies that a Linux kernel image exists in NAND, then copies it to RAM and starts the IO-Link Master. The U-Boot version is displayed after the image name.
FPGA	The FPGA partition/image contains configuration data used by programmable hardware within the IO-Link Master unit. FPGA images are unique to the hardware and protocol type. Make sure you download the correct image for your platform.

<b>IO-Link Master Images</b>	
ulmage - Primary/ Backup	<p>The ulmage contains the Linux kernel and the RAM-resident root file system. It does not contain industrial protocol support or application-specific features.</p> <p>There is a Primary and Backup version loaded on the IO-Link Master. The IO-Link Master automatically reloads the Backup ulmage if the file system corrupted.</p> <p>The ulmage version is displayed after the Primary/Backup ulmage.</p>
Application Base	<p>The Application Base image comprises a flash-resident file system containing applications and protocol support.</p> <p>The Application Base is built from a collection of application subassemblies -- each of which may be updated individually between releases of the application base as a whole.</p> <p>The application subassemblies in the Application Base image are displayed in the lower portion of the <b>SOFTWARE</b> page.</p> <p>The Application Base assembly has a 3-tuple version number: (for example, 1.3.18).</p>

**5.1.2 Application Subassemblies**

Application subassemblies are the components of the Application Base image. Application subassemblies have a 4-tuple version number (for example, 1.3.18.3). The first two values in a subassembly version correspond to the version of the application base assembly for which it was built and tested.

For example, a subassembly with version 1.3.18.3 was tested with application base version 1.3.18. When using the **Software** page or PortVision DX, an application subassembly can install only if its version number matches that of the installed application base assembly. A subassembly with a version of 1.20.2.4 only installs if the application base version is 1.20.2. It will not install on a device with application base version 1.21.5.

<b>IO-Link Master Application Subassemblies</b>	
application-manager	The Application Manager version loaded on the IO-Link Master.
configuration-manager	The Configuration Manager version loaded on the IO-Link Master.
discovery-protocol	The Discovery Protocol version loaded on the IO-Link Master.
event-log	The Event log version loaded on the IO-Link Master.
iolink-driver	The IO-Link driver version loaded on the IO-Link Master.
io-link manager	The IO-Link manager version loaded on the IO-Link Master, which provides support for PROFINET IO.
profinetio	The PROFINET IO version loaded on the IO-Link Master.
web-help	The web interface help version loaded on the IO-Link Master.
web-user-interface	The web interface version loaded on the IO-Link Master.

**5.2 Using the Web Interface to Update Software**

The upper portion of the **Advanced | Software** page is used to update the IO-Link Master images. The lower portion of this page is used for updating application subassemblies that are integrated in the Application Base.

Typically, the latest application subassemblies are available in the Application Base image. There may times when a feature enhancement or bug fix is available in an application subassembly and not yet available in the Application Base image.

**5.2.1 Updating Images**

Use this procedure to upload images using the **SOFTWARE** page.

1. Download the latest image from the Leuze electronic web site.

*Note: Make sure that you download the appropriate software for your model. For example, the FPGA images are unique for different hardware models and protocol.*

2. Open your browser and enter the IP address of the IO-Link Master.
3. Click **Advanced | SOFTWARE**.
4. Click the **UPDATE** button next to the image you want to update.
5. Click the **Browse** button, navigate to the file location, highlight the image, and click **Open**.
6. Click the **Install** button.

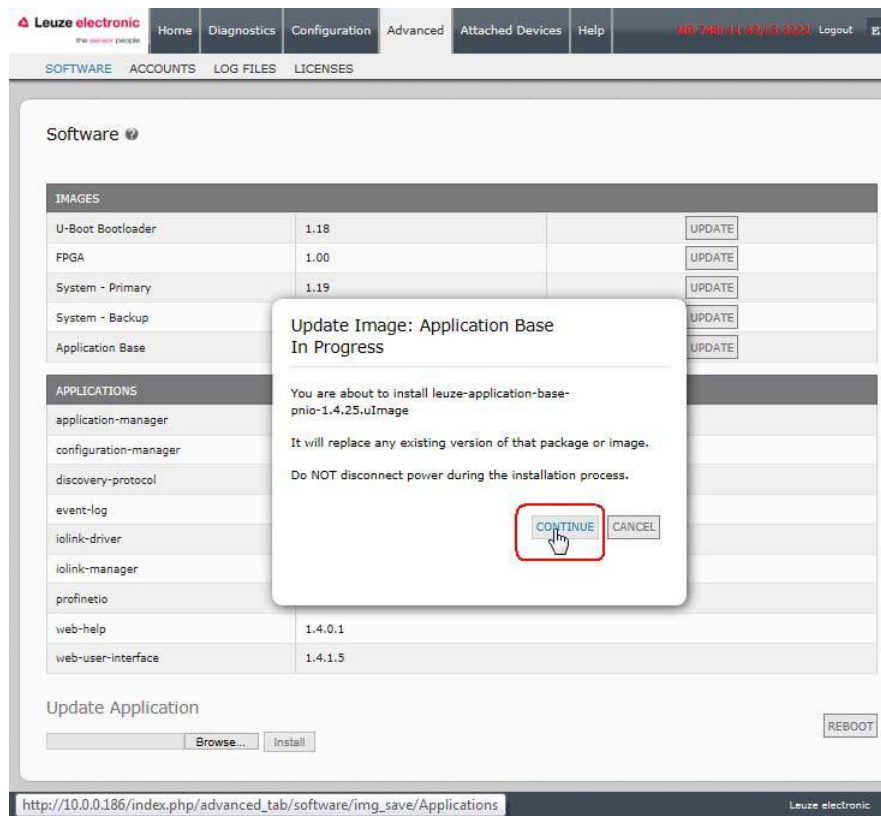

Figure 23: Update software application base

7. Click the **CONTINUE** button to the *Update Image* message.
  8. Click **OK** to close the *Update Image Successful* message.
- Note: Some images may require the IO-Link Master web server to restart.*

### 5.2.2 Updating Application Subassemblies

Use this procedure to upload applications using the **Software** page.

1. Download the latest application from the Leuze electronic web site.
2. Open your browser and enter the IP address of the IO-Link Master.
3. Click **Advanced** and **SOFTWARE**.
4. Click the **Browse** button under **Update Application** navigate to the file location, highlight the application, and click **Open**.
5. Click the **Install** button.
6. Click the **CONTINUE** button to the *Update Application* message.

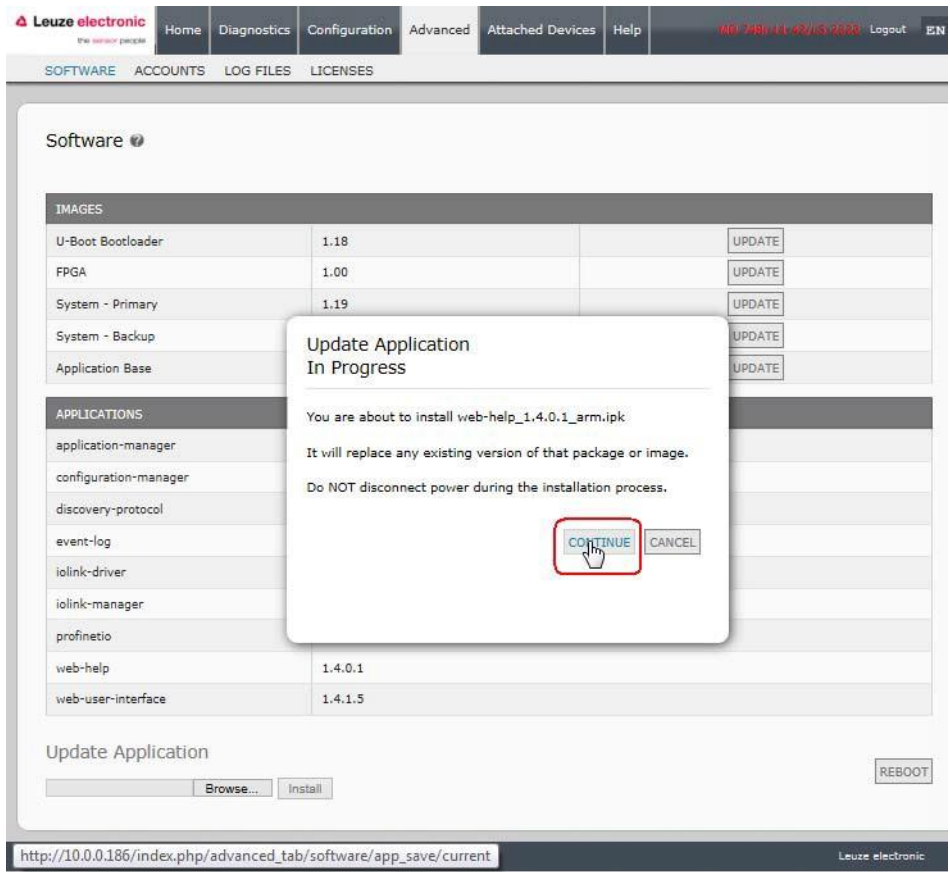

Figure 24: Update software application base

7. Click **OK** to close the *Update Application Successful* message.

## 6 Connecting Devices

This chapter discusses connecting devices to the IO-Link Master.

### 6.1 Connecting Devices to IO-Link Ports

Use the appropriate discussion for your IO-Link Master model.

- MD 748i-11-42/L5-2222 IO-Link Ports
- MD 248i-12-8K/L4-2R2K IO-Link Ports

#### 6.1.1 MD 748i-11-42/L5-2222 IO-Link Ports

The MD 748i-11-42/L5-2222 provides four IO-Link ports (depending on the model) with M12, 5-pin female/A coded connectors.

This table provides signal information for the IO-Link connectors.

Pin	Signal	Description
1	L+	Power supply (+)
2	DI	Digital input
3	L-	Power supply (-)
4	C/Q	Communication signal, which supports SDCI (IO-Link) or SIO (standard input/output)
5	N/A	Not connected

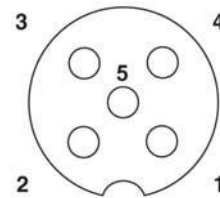

The standard SDCI (IO-Link) transmission rates are supported:

- COM1 4.8Kbps
- COM2 38.4Kbps
- COM3 230.4Kbps

This table provides current and power information that you may need regarding the IO-Link ports.

Current and Power	MD 748i-11-42/ L5-2222
Maximum C/Q Current	200mA (total 800mA)
Maximum L+/L- Current Output	500mA (total 2000mA)
C/Q & DI Input:	Power Input
Maximum (L+)	+0.5VDC
Minimum (L-)	-0.5VDC

Use the following procedure to attach IO-Link or digital input/output devices to the ports.

1. Securely attach the IO-link cable between the IO-Link or digital input/output device and the IO-Link port.  
*Note: Make sure that you tighten the cables properly to maintain IP67 integrity.*
2. If necessary, securely attach a connector cap to prevent dust or liquids from getting into any unused ports. Connector caps were shipped with the IO-Link Master.  
*Note: IO-Link ports must have an approved cable or protective cover attached to the port to guarantee IP67 compliance.*
3. If necessary, configure IO-Link port parameters using the **Configuration | IO-Link Settings** page to configure the port mode.
  - If an IO-Link device is attached to the port, the IO-Link LED should now be lit green and the device is receiving power.
  - If a digital input or output device is attached to the IO-Link port, after the port is configured for

digital input or output on the **IO-Link Settings** page, the IO-Link LED does not light but when an event occurs:

- Digital input causes the DI LED to flash.
- Digital output causes the IO-Link LED to flash

You can refer to the help system or chapter 3 Configuring the IO-Link Master with STEP 7 for configuration information.

### 6.1.2 MD 248i-12-8K/L4-2R2K IO-Link Ports

The following provides information about the IO-Link ports.

Signal	Description	Value
L+	Power Supply Output (+)	200mA @ 24V (Maximum)
L-	Power Supply Output (-)	
DI	Digital Input	Not applicable.
C/Q	Communication signal, which supports SDCI (IO-Link) or SIO (standard input/output)	200mA @ 24V (Maximum)



Use the appropriate procedure to connect devices to the IO-Link ports.

- *Connecting IO-Link Devices*
- *Connecting Digital Input Devices to IO-Link Ports*

#### 6.1.2.1 Tips When Connecting Devices to the MD 248i-12-8K/L4-2R2K

The following tips may be useful when connecting devices to the MD 248i-12-8K/L4-2R2K because it may be difficult to manipulate the wire-clamp screws on the adjacent ports.

- If you are going to connect devices to Digital I/O ports (**D1** through **D4**), connect the digital devices before connecting devices to IO-Link ports.
- Connect a device to IO-Link Port 1 before IO-Link Port 2
- Connect a device to IO-Link Port 4 before IO-Link Port 3
- Connect a device to IO-Link Port 5 before IO-Link Port 6
- Connect a device to IO-Link Port 8 before IO-Link Port 7

#### 6.1.2.2 Connecting IO-Link Devices

Use the following procedure to connect IO-Link devices to the IO-Link ports.

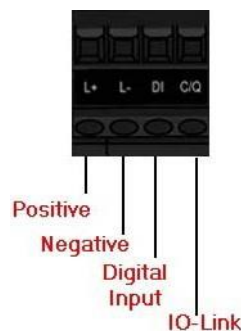

1. Insert the IO-Link device negative wire into the **L-** contact and tighten the wire-clamp screws to prevent the wire from coming loose.

2. Insert the IO-Link device positive wire into the **L+** contact and tighten the wire-clamp screws to prevent the wire from coming loose.
3. If applicable, insert the DI wire into the **DI** contact and tighten the wire-clamp screws to prevent the wire from coming loose.
4. Insert the IO-Link wire into the **C/Q** contact and tighten the wire-clamp screws to prevent the wire from coming loose.
5. If necessary, configure IO-Link parameters for each port. Refer to the help system for detailed port configuration information.

### 6.1.2.3 Connecting Digital Input Devices to IO-Link Ports

You can use an IO-Link port as a digital in port if you wish to do so.

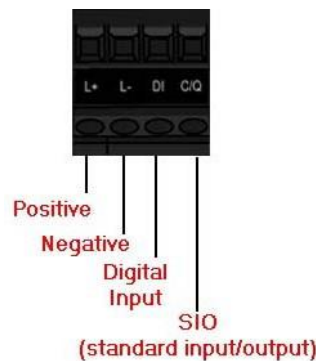

1. Insert the IO-Link device negative wire into the **L-** contact and tighten the wire-clamp screws to prevent the wire from coming loose.
2. Insert the IO-Link device positive wire into the **L+** contact and tighten the wire-clamp screws to prevent the wire from coming loose.
3. If applicable, insert the DI wire into the **DI** contact and tighten the wire-clamp screws to prevent the wire from coming loose.
4. Refer to the help system for detailed port configuration information.

### 6.1.2.4 Connecting DIO Devices to IO-Link Ports

You can use an IO-Link port to connect and operate a digital input or output device.

1. Insert the IO-Link device negative wire into the **L-** contact and tighten the wire-clamp screws to prevent the wire from coming loose.
2. Insert the IO-Link device positive wire into the **L+** contact and tighten the wire-clamp screws to prevent the wire from coming loose.
3. If applicable, insert the DI or DO wire into the **C/Q** contact and tighten the wire-clamp screws to prevent the wire from coming loose.
4. Refer to the help system for detailed port configuration information.

## 6.2 Connecting Devices to the Digital IO Ports (MD 248i-12-8K/L4- 2R2K)

The MD 248i-12-8K/L4-2R2K provides two digital input (DI) ports and two digital IO ports.

Signal	Description	Specifications
L+	Power Supply (+)	200mA @ 24V (maximum)
L-	Power Supply (-)	
DI	Digital Input	
DIO	Digital I/O	200mA @ 24V (maximum)



You can connect a digital input device to DI and/or DIO. DIO supports digital out.

### 6.2.1 Connecting to DI

Use this procedure to connect a digital input device using the **DI** terminal on a DIO port.



D1 or D3 LEDs

1. Insert the IO-Link device negative wire into the **L-** contact and tighten the wire-clamp screws to prevent the wire from coming loose.
2. Insert the IO-Link device positive wire into the **L+** contact and tighten the wire-clamp screws to prevent the wire from coming loose.
3. Insert the DI wire into the **DI** contact and tighten the wire-clamp screws to prevent the wire from coming loose.
4. Go to the **Configuration | Digital I/O Settings** page to configure the port. If necessary, refer to the help system.

### 6.2.2 Connecting to DIO



D2 or D4 LEDs

1. Insert the IO-Link device negative wire into the **L-** contact and tighten the wire-clamp screws to prevent the wire from coming loose.
2. Insert the IO-Link device positive wire into the **L+** contact and tighten the wire-clamp screws to prevent the wire from coming loose.
3. Insert the DI wire into the **DIO** contact and tighten the wire-clamp screws to prevent the wire from coming loose.
4. Go to the **Configuration | Digital I/O Settings** page to configure the port. If necessary, refer to the help system or chapter 7 Dedicated Digital I/O Port Configuration.

## 7 Dedicated Digital I/O Port Configuration

This section discusses dedicated digital IO port (D1 through D4) configuration, including:

- *Digital I/O Settings Page*
- *Editing Digital I/O Settings*
- *Digital I/O Setting Parameters*

### 7.1 Digital I/O Settings Page

Use the **Configuration | Digital I/O** page to configure the dedicated DIO port characteristics for the IO-Link Master. **D1** and **D2** are located next to IO-Link Port 1 and **D3** and **D4** are located next to IO-Link Port 4.

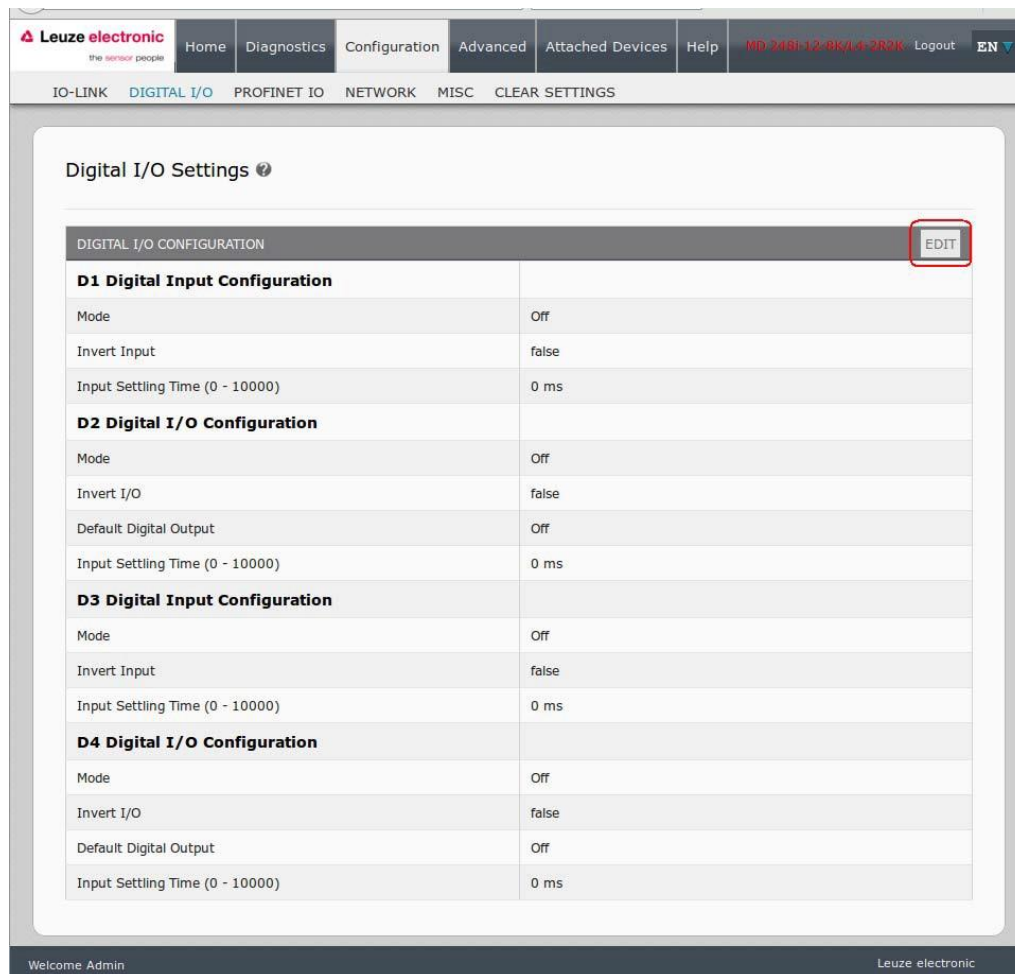

Figure 25: Digital I/O settings

### 7.2 Editing Digital I/O Settings

You can use this procedure to configure digital I/O characteristics for the digital I/O ports.

1. If necessary, open the IO-Link Master web interface with your web browser using the IP address.
2. Click **Configuration | Digital I/O**.
3. Click the **EDIT** button.
4. Make appropriate selections for the digital I/O device or devices that you will connect to the ports. You can use the help system if you require definitions or values for the options or Digital I/O Setting Parameters.

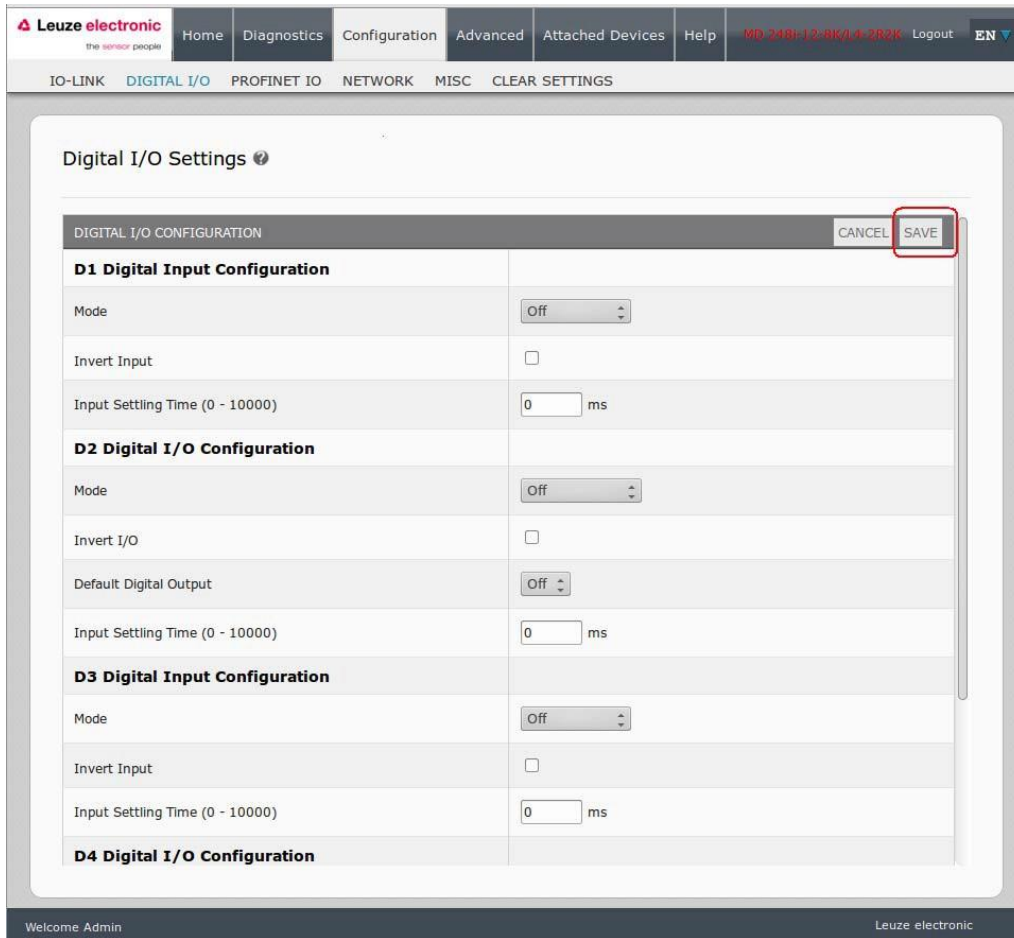

Figure 26: Save Digital I/O settings

5. Click the **SAVE** button.

### 7.3 Digital I/O Setting Parameters

The **Configuration | Digital I/O Settings** page supports the following options.

Digital I/O Settings Page	
<b>D1 Digital Input Configuration</b>	
Mode <i>Default = Off</i>	Selects the <b>Mode</b> : <ul style="list-style-type: none"> <li>• <b>Off</b> – No monitoring of the digital input pin.</li> <li>• <b>Digital-Input</b> – monitors the digital input status</li> </ul>
Invert Input <i>Default = False</i>	If <b>Mode</b> is set to <b>Digital-Input</b> , the input status is inverted.
Input Settling Time (0 - 10000ms) <i>Default = 0ms</i>	If non-zero and <b>Mode</b> is set to <b>Digital-Input</b> , the required time that the input status must remain constant before an input status change is reported.

<b>Digital I/O Settings Page</b>	
<b>D2 Digital I/O Configuration</b>	
Mode <i>Default = Off</i>	Selects the <b>Mode</b> : <ul style="list-style-type: none"> <li>• <b>Off</b> – No monitoring or setting of the digital I/O pin.</li> <li>• <b>Digital-Input</b> – monitors the digital input status</li> <li>• <b>Digital-Output</b> – sets the digital output to either the default setting or value received from a controller.</li> </ul>
Invert I/O <i>Default = False</i>	If selected: <ul style="list-style-type: none"> <li>• If <b>Mode</b> is set to <b>Digital-Input</b>, the input status is inverted.</li> <li>• If <b>Mode</b> is set to <b>Digital-Output</b>, the output setting is inverted.</li> </ul>
Default Digital Output <i>Default = Off</i>	If <b>Mode</b> is set to <b>Digital Output</b> , defines the default digital output setting: <ul style="list-style-type: none"> <li>• At startup before a controller can set the digital output.</li> <li>• When communication to all controller(s) has been lost.</li> </ul> Possible settings: <ul style="list-style-type: none"> <li>• <b>Off</b> - low voltage</li> <li>• <b>On</b> – high voltage</li> </ul>
Input Settling Time (0 - 10000ms) <i>Default = 0ms</i>	If non-zero and <b>Mode</b> is set to <b>Digital-Input</b> , the required time that the input status must remain constant before an input status change is reported.
<b>D3 Digital Input Configuration</b>	
Mode <i>Default = Off</i>	Selects the <b>Mode</b> : <ul style="list-style-type: none"> <li>• <b>Off</b> – No monitoring of the digital input pin.</li> <li>• <b>Digital-Input</b> – Monitors the digital input status</li> </ul>
Invert Input <i>Default = False</i>	If <b>Mode</b> is set to <b>Digital-Input</b> , the input status is inverted.
Input Settling Time (0 - 10000) <i>Default = 0ms</i>	If non-zero and <b>Mode</b> is set to <b>Digital-Input</b> , the required time that the input status must remain constant before an input status change is reported.
<b>D4 Digital I/O Configuration</b>	
Mode <i>Default = Off</i>	Selects the <b>Mode</b> : <ul style="list-style-type: none"> <li>• <b>Off</b> – No monitoring or setting of the digital I/O pin.</li> <li>• <b>Digital-Input</b> – Monitors the digital input status</li> <li>• <b>Digital-Output</b> – sets the digital output to either the default setting or value received from a controller.</li> </ul>
Invert I/O <i>Default = False</i>	If selected: <ul style="list-style-type: none"> <li>• If <b>Mode</b> is set to <b>Digital-Input</b>, the input status is inverted.</li> <li>• If <b>Mode</b> is set to <b>Digital-Output</b>, the output setting is inverted.</li> </ul>
Default Digital Output <i>Default = Off</i>	If <b>Mode</b> is set to <b>Digital Output</b> , defines the default digital output setting: <ul style="list-style-type: none"> <li>• At startup before a controller can set the digital output.</li> <li>• When communication to all controller(s) has been lost.</li> </ul> Possible settings: <ul style="list-style-type: none"> <li>• <b>Off</b> – low voltage</li> <li>• <b>On</b> – high voltage</li> </ul>

Digital I/O Settings Page	
Input Settling Time (0 - 10000) <i>Default = 0ms</i>	If non-zero and <b>Mode</b> is set to <b>Digital-Input</b> , the required time that the input status must remain constant before an input status change is reported.

## 8 Loading and Managing IODD Files

There are several **Attached Devices** pages that support IO-Link Device Description (IODD) file management.

- *IO-Link Device Description Files Page - load IODD files from the IO-Link device manufacturer onto the IO-Link Master.*
- *IO-Link Device Configuration Summary Page - verify the correct files were loaded for each IO-Link device.*
- *The Port pages are discussed in chapter 9 Configuring IO-Link Devices*

### 8.1 IO-Link Device Description Files Page

Use the **IO-Link Device Description Files** page to update (upload) and delete IO-Link Device Description (IODD) files associated with this IO-Link Master. In addition, you can review the IODD **xml** file by clicking the **IODD FILENAME** in the table after loading the IODD file.

**Note:** You will need to download the appropriate IODD files from your IO-Link device manufacturer.

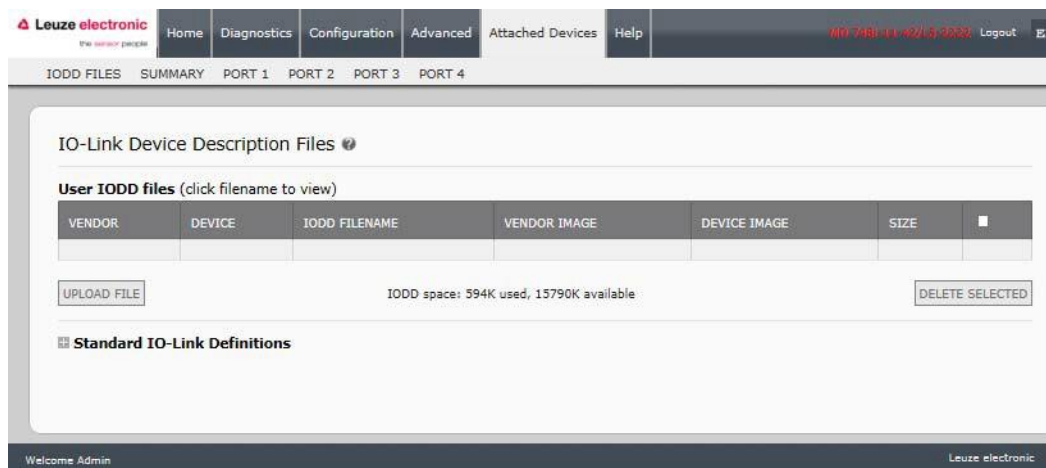

Figure 27: IO-Link Device Description files page

The IO-Link Master provides 15790K of space to store IODD files. The IO-Link Master includes the following default IODD files, which cannot be deleted.

- IODD-StandardDefinitions1.0.1.xml
- IODD-StandardUnitDefinitions1.0.1.xml
- IODD-StandardDefinitions1.1.xml
- IODD-StandardUnitDefinitions1.1.xml

#### 8.1.1 Preparing IODD Files to Upload

After downloading the IODD files for the IO-Link device from the IO-Link sensor or actuator manufacturer, you may need to unzip the file and locate the appropriate **xml** file for the device.

- Some IODD zip files contain the **xml** files and supporting image files for a single product. This type of zip file can be immediately loaded onto the IO-Link Master.
- Some IODD zip files contain the files for multiple products. If you upload this type of IODD zip file, the IO-Link Master loads the first xml file and the associated image files, which may or may not correspond to the IO-Link device connected to the port. If you need to zip the appropriate files, the following information may be useful:
  - Unzip the package and locate the **xml** file needed for your IO-Link device.
  - Open the xml file and search for the **productID**, which identifies the IO-Link device.

- Zip the **xml** file along with the supporting images. There are several ways to locate the supporting images:
  - Locate the appropriate images using the **xml** file.
  - Load only the **xml** file and the IO-Link Master notifies you what files are missing. Use the **UPDATE** feature to upload the missing images.
  - Zip the **xml** with all of the images and the IO-Link Master ignores (and not upload) any unused files and notifies which files did not upload.

*Note: Image files are not required for IO-Link device configuration.*

Use the appropriate discussion for your IODD files.

- *Uploading IODD Zip Files*
- *Uploading xml Files or Supporting Files*

### 8.1.2 Uploading IODD Zip Files

You can use the following procedure to upload IODD zip files.

1. Click **Attached Devices** and **IODD FILES**.
2. Click the **UPLOAD FILE** button.
3. Click the **CHOOSE FILE** button and browse to the file location.
4. Highlight the **zip** file, click **Open** and then the **UPLOAD** button.

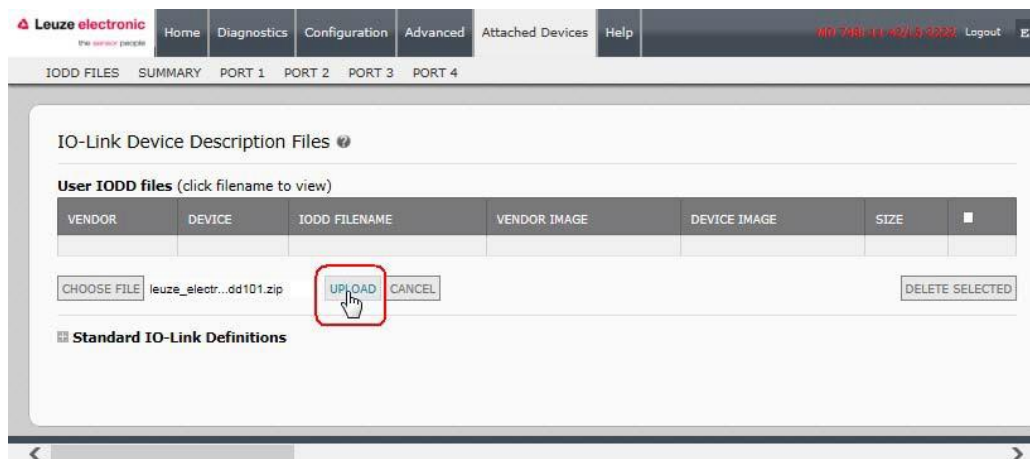

Figure 28: Upload IO-Lin Device Description file

5. If necessary, click **Ok**.

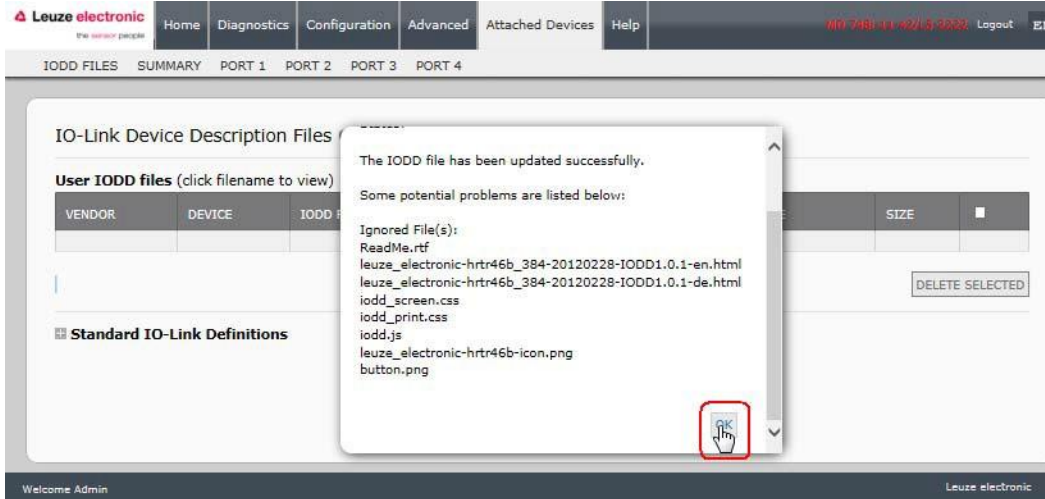

Figure 29: Confirm upload

**Note:** Only images referenced in the xml file load to the IO-Link Master and the remaining files are ignored.

6. If desired, you can view the **xml** file by clicking the **IODD FILENAME** in the table.

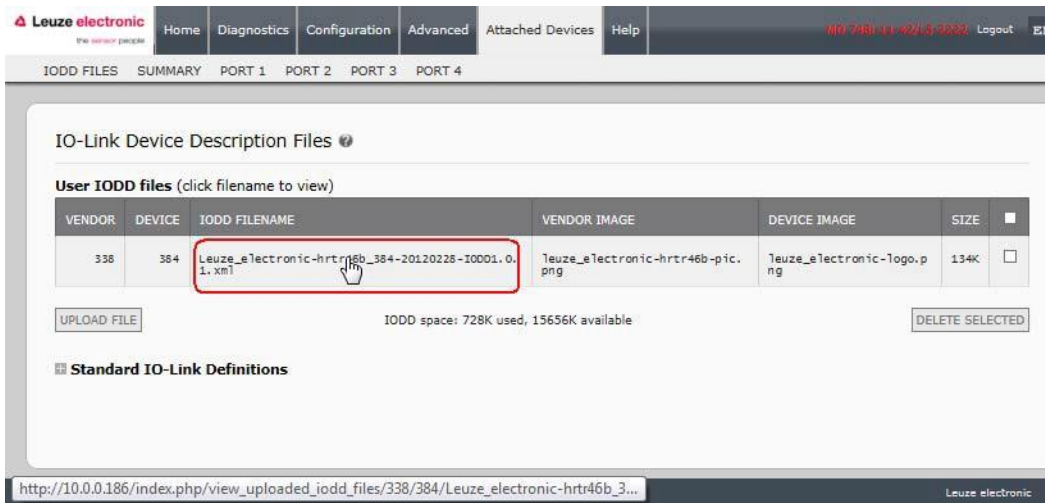

Figure 30: View IODD file

7. Click the hyperlink at the top of the page if you want to view the **xml** file in your browser.

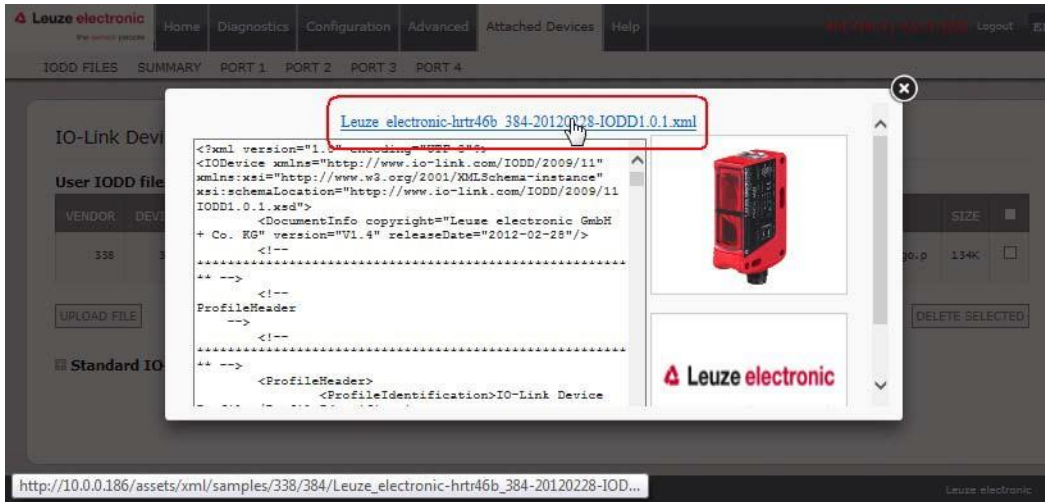

Figure 31: Open IODD file in your browser

8. Optionally, verify that the correct xml file was loaded using the **Summary** page.

### 8.1.3 Uploading xml Files or Supporting Files

You can use the following procedure to upload xml, or supporting image files.

1. Click **Attached Devices** and **IODD FILES**.
2. Click the **UPLOAD FILE** button.
3. Click the **CHOOSE FILE** button and browse to the file location.
4. Highlight the xml or image file and click **Open**.

*Note:* The xml file must be loaded before the IO-Link Master will load the associated image files.

5. Click the **UPLOAD** button.

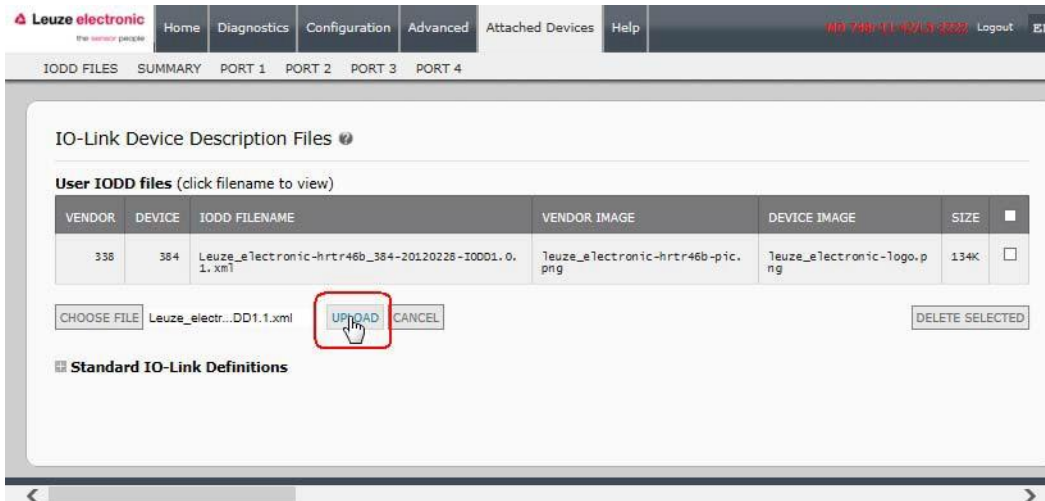

*Note:* The IO-Link Master notifies you what files are missing. The missing files do not affect the operation of the IODD Port page but the product image and logo for the IO-Link device company do not display.

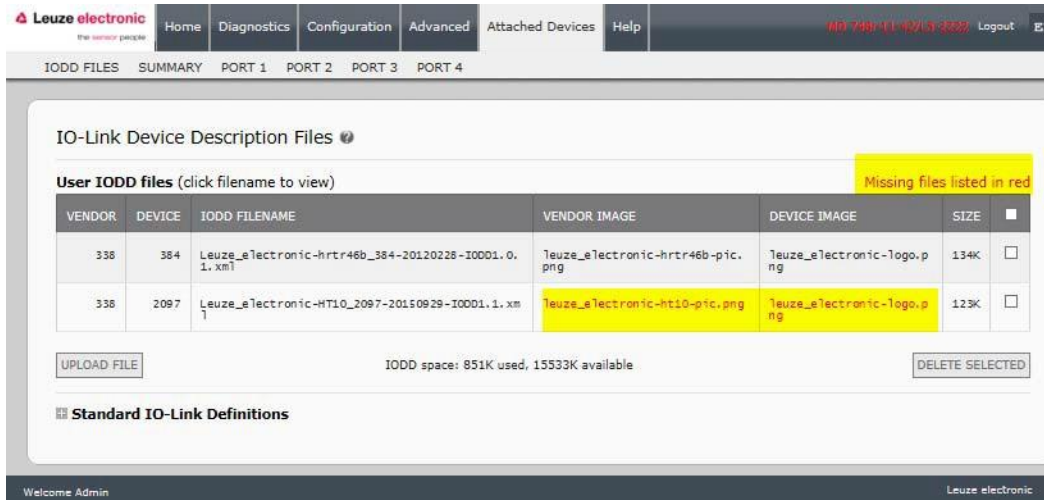

Figure 32: Notification of missing files

6. Optionally, use the following steps to load image files:
  - a. Select the row in the table that contains the **xml** file.
  - b. Click the **UPLOAD FILE** button and browse to the file location.

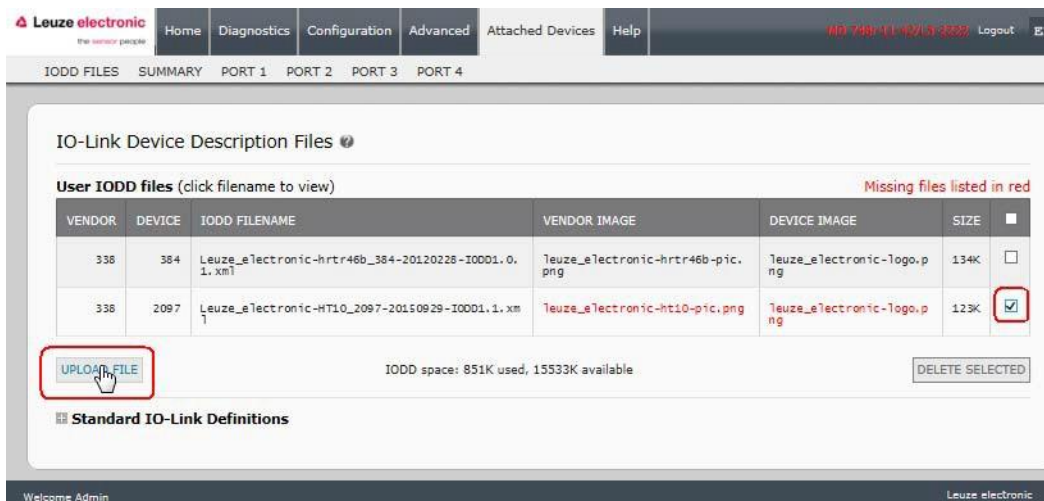

Figure 33: Upload file for highlighted device

- c. Highlight the file and click **Open**.
- d. Click the **UPLOAD** button.
- e. If desired, you can view the **xml** file by clicking the **IODD FILENAME** in the table.
- f. Optionally, verify that the correct **xml** file was loaded using the **Summary** page.

### 8.1.4 Viewing and Saving IODD Files

Use the following procedure to view the contents of an IODD file.

1. If necessary, click **Attached Devices** and **IODD Files**.
2. Click the **IODD FILENAME** in the table that you want to review. A pop up window displays the contents of the IODD file.
3. Optionally, click the file name hyperlink at the top of the window to view the formatted file or if you want to save a copy of the file to another location.

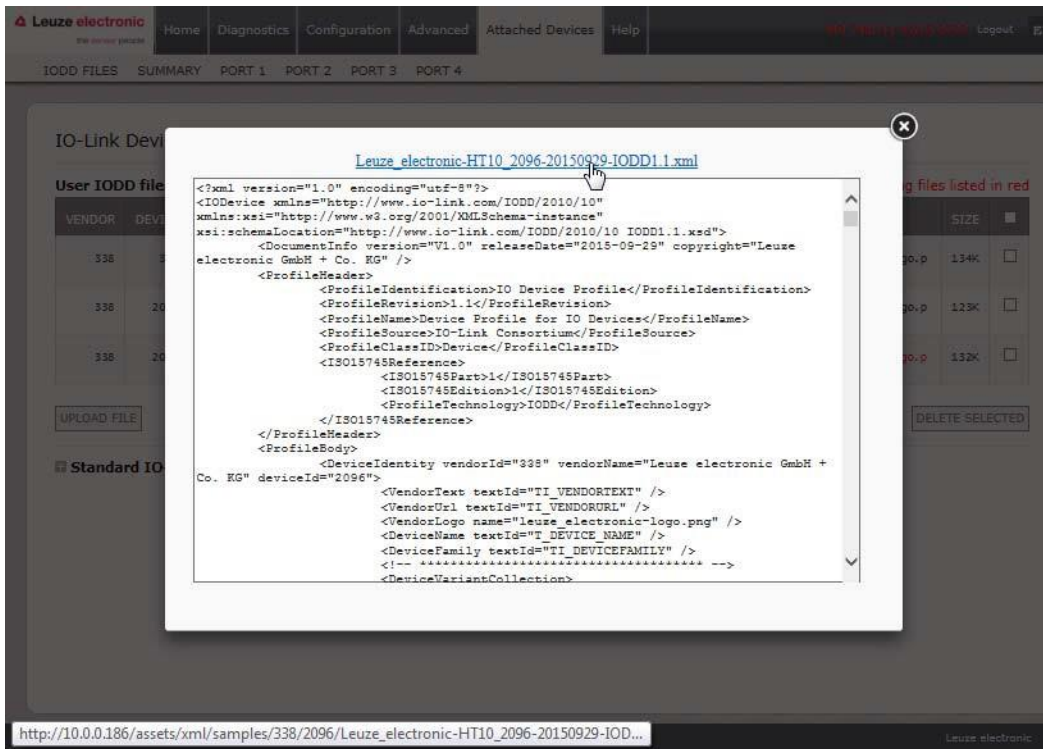

### 8.1.5 Deleting IODD Files

Use the following procedure to delete an IODD file set from the IO-Link Master.

1. If necessary, click **Attached Devices** and **IODD Files**.
2. Check the corresponding row of the IODD file that you want to delete.
3. Click the **DELETE SELECTED** button.

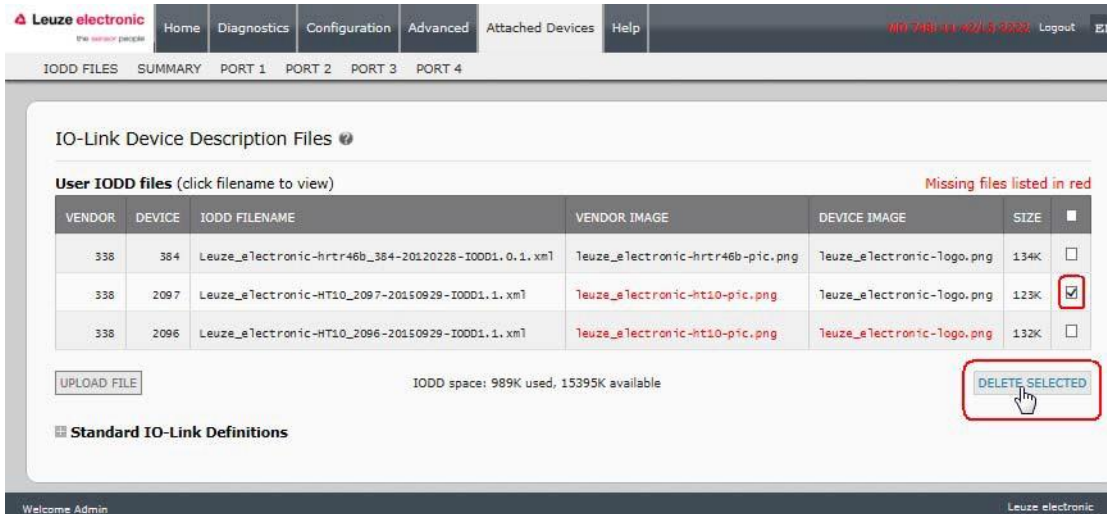

Figure 34: Deleting IODD files

4. Click **CONTINUE** to the *Delete files?* message.

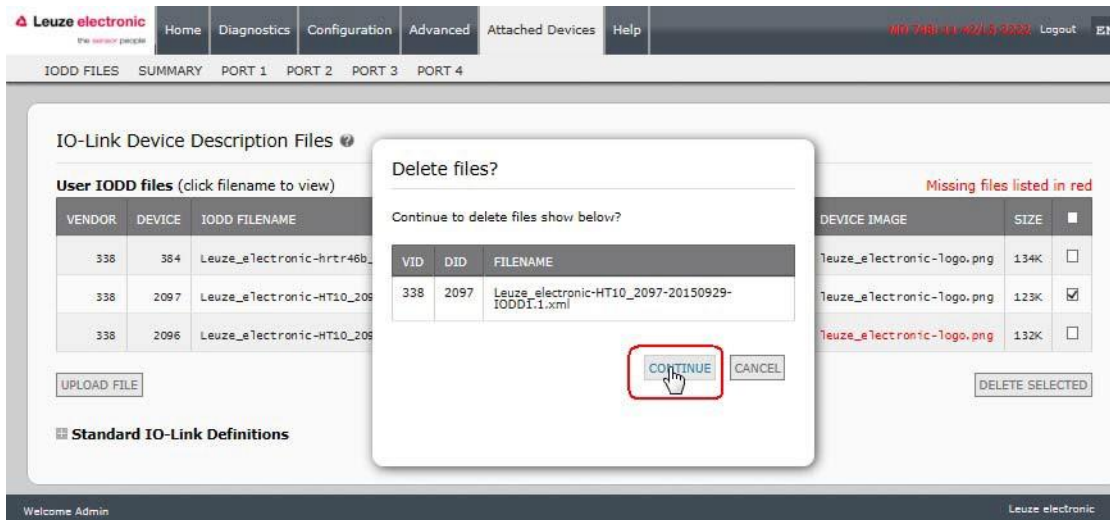

Figure 35: Confirm deleting of IODD files

## 8.2 IO-Link Device Configuration Summary Page

The **IO-Link Device Configuration Summary** page provides basic device configuration (device profile) information for ports with valid IO-Link devices attached. The **Configuration Summary** page retrieves information that resides on the IO-Link device from the manufacturer.

A file name displayed in the **IODD Name** field for a port indicates that a valid IODD file is associated with that device. If the field is empty, that indicates that a valid IODD file has not been loaded.

You can review complete IODD file information on a port by port basis by clicking the **MORE** button next to the port in question or by clicking the **PORT** menu selection in the navigational bar.

Use the following steps to access the **IO-Link Device Configuration Summary** page.

1. Click **Attached Devices**.
2. Click **SUMMARY**.

*Note: The **Configuration Summary** page takes several minutes to completely load as each device is queried.*

3. Click the **MORE** button or the corresponding **Port** (in the navigational bar) to configure the IO-Link device parameters for a specific device. See chapter 9 Configuring IO-Link Devices for more information.

IO-Link Device Configuration Summary

DEVICE SETTINGS	PORT1	MORE	PORT2	MORE	PORT3	MORE	PORT4	MORE
Vendor Name	Leuze electronic GmbH + Co. KG		Leuze electronic GmbH + Co. KG		Leuze electronic GmbH + Co. KG			
VENDOR	338		338		338			
DEVICE	289		2096		384			
Description								
IO-Link Version	1.0		1.1		1.1			
Hardware Version	L		B000		C			
Firmware Version	02.20		1.1		01.15			
Baud Rate	38400		38400		38400			
SIO Mode	Yes		Yes		Yes			
Min Cycle Time	2.5 ms		2.3 ms		7.2 ms			
IODD Name			Leuze_electronic-HT10_2096-2-0150929-IODD1.1.xml		Leuze_electronic-htr46b_384-20120228-IODD1.0.1.xml			
Serial Number	1408L068197		01540018205		1111C000485			

Figure 36: IO-Link summary page

## 9 Configuring IO-Link Devices

This chapter discusses using the **Attached Devices | Port** pages to change IO-Link device parameters.

*Note: Optionally, you can use traditional methods such as: PLC interfaces to configure the IO-Link devices.*

### 9.1 Port Pages Overview

You can use the **Attached Devices | Port** page for a port to review and easily edit the IO-Link device configuration.

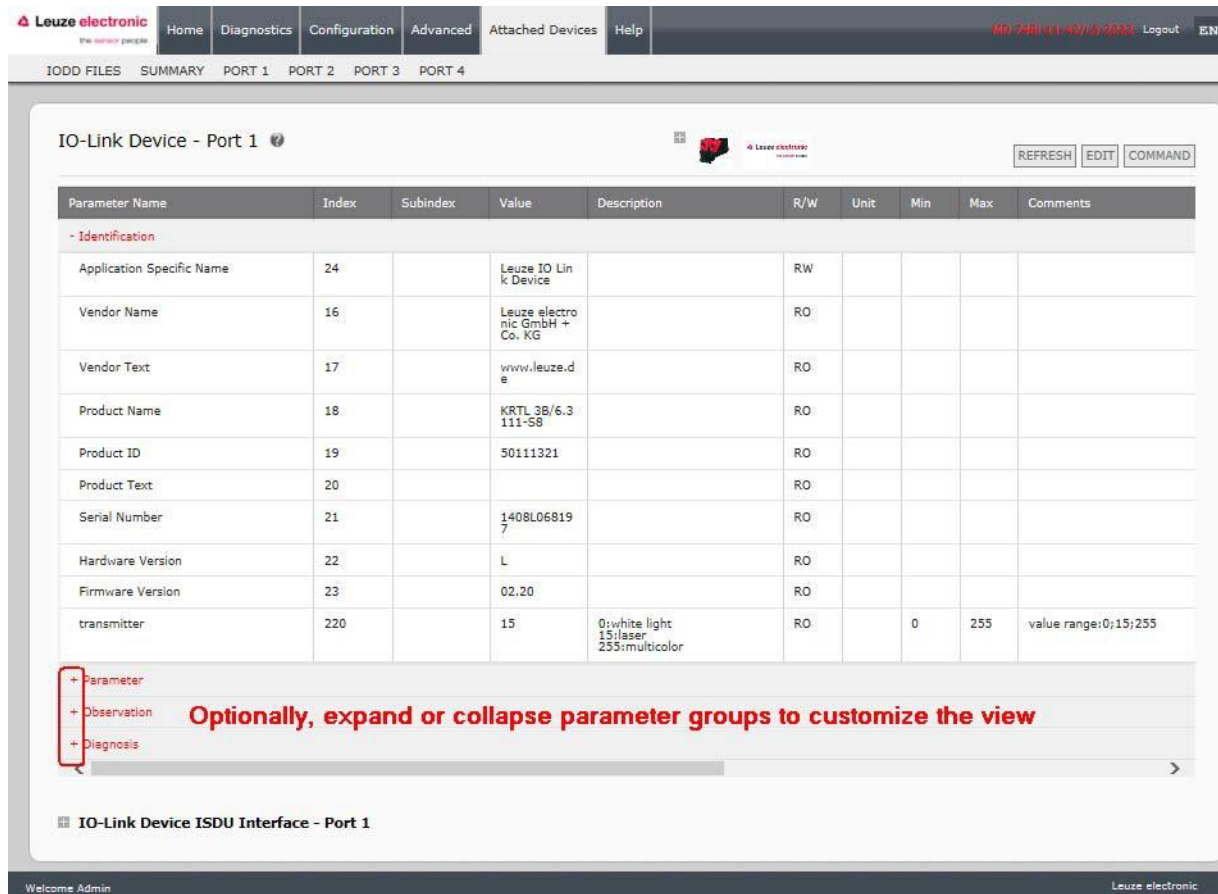

Figure 37: IO-Link port overview page

The **Port** page provides two IO-Link device configuration methods:

- **IO-Link Device Port** table (GUI), which depends on the appropriate IODD file loaded from the IO-Link device manufacturer onto the IO-Link Master. To use the **IO-Link Device Port** table for configuring IO-Link devices, refer to the following subsections:
  - *Editing Parameters - IO-Link Device - Port Table*
  - *Resetting IO-Link Device Parameters to Factory Defaults*
- **IO-Link Device ISDU Interface - Port**, which can be used with or without IODD files loaded. Refer to the following information to use the **IO-Link Device ISDU Interface - Port** method:
  - The *IO-Link Device Operator Manual* from the device manufacturer is needed to use the **IO-Link Device ISDU Interface** since ISDU block index and ISDU sub-index numbers are required.
  - *Editing Parameters - IO-Link Device ISDU Interface - Port*

### 9.2 Editing Parameters - IO-Link Device - Port Table

Use the following procedure to edit IO-Link device parameters using the **IO-Link Device Port** table.

**Note:** You may want to verify that the **Automatic Download Enable for Data Storage** option on the **Configuration / IO-Link Settings** page is **NOT** set to **On** as this can cause unreliable results on the corresponding port.

1. If you have not done so, load the IODD file from the IO-Link device manufacturer (chapter 8 Loading and Managing IODD Files).
2. Access the appropriate **Port** page by clicking **Attached Devices** and then the **Port** number that you want to configure.
3. Click the **EDIT** button after all of the device information is populated in the table.
4. Scroll down the table and make appropriate parameter changes for your environment.

**Note:** An IODD file may not contain every IO-Link device setting depending on the IO-Link device manufacturer. If you need to change a parameter that is not displayed in the **IO-Link Device - Port** table, you can refer to the IO-Link device Operators Manual and use the **IO-Link Device ISDU Interface** to change the settings.

You may need to scroll to the right in the table to view applicable parameter values if the parameter is not selectable in a drop list.

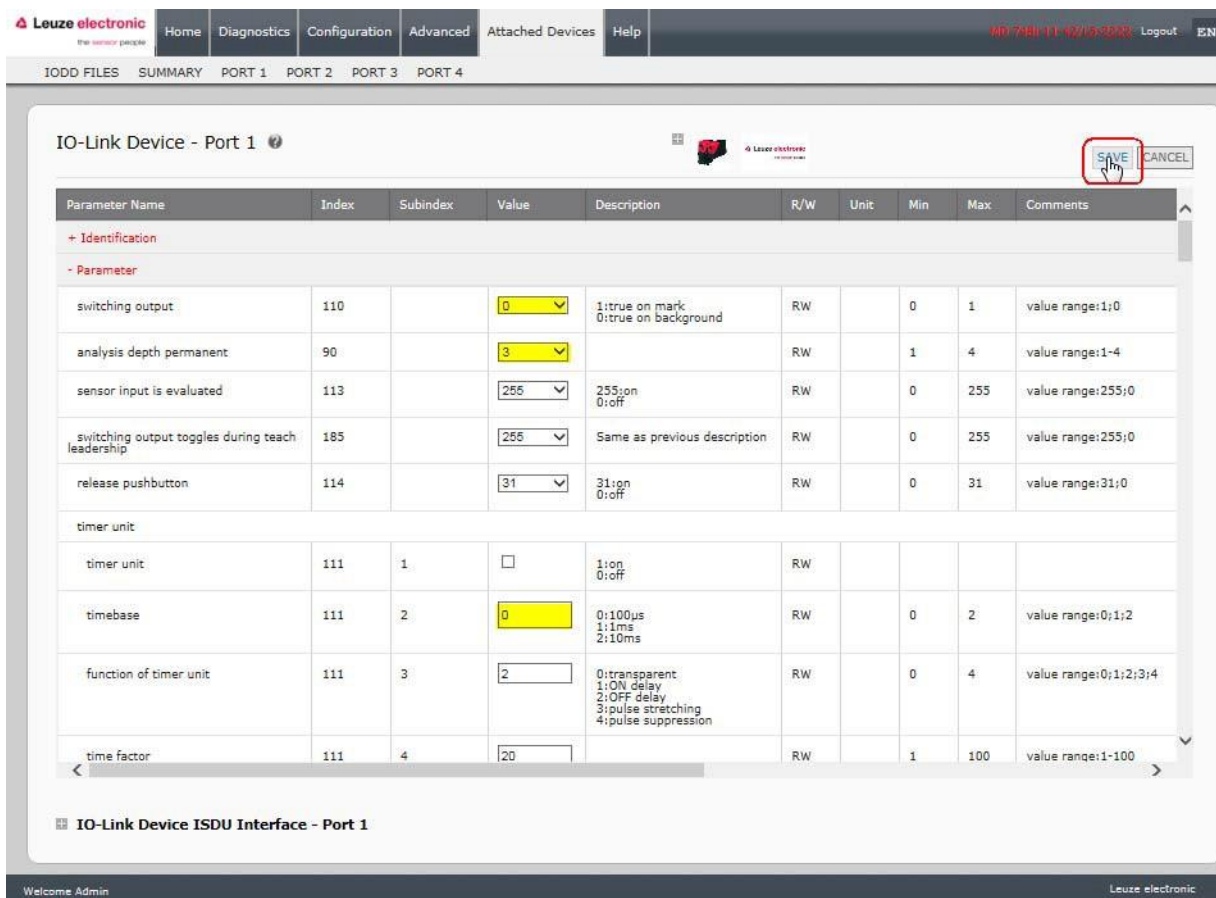

Figure 38: IO-Link device settings

5. Click the **SAVE** button after editing the parameters.

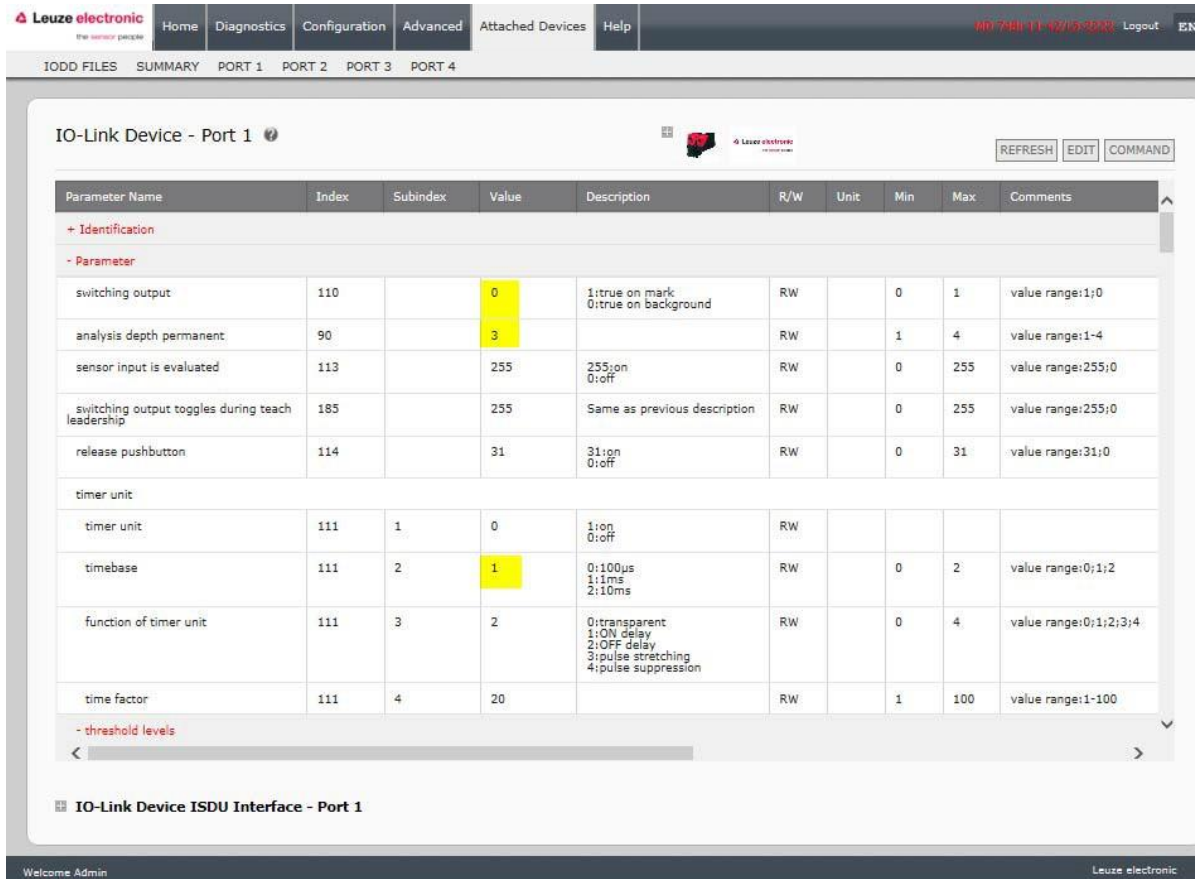

Figure 39: Save IO-Link device settings

### 9.3 Resetting IO-Link Device Parameters to Factory Defaults

In the event you want to reset the IO-Link device to factory default, typically the IODD file provides the ability from the IO-Link device manufacturer. Use the following example to reset an IO-Link device.

1. Click the **COMMAND** button and locate the **Restore Factory** button.
2. Click the **Restore Factory** or **Load Factory Settings** button.

**Note:** The name of the button is determined by the IO-Link device manufacturer.

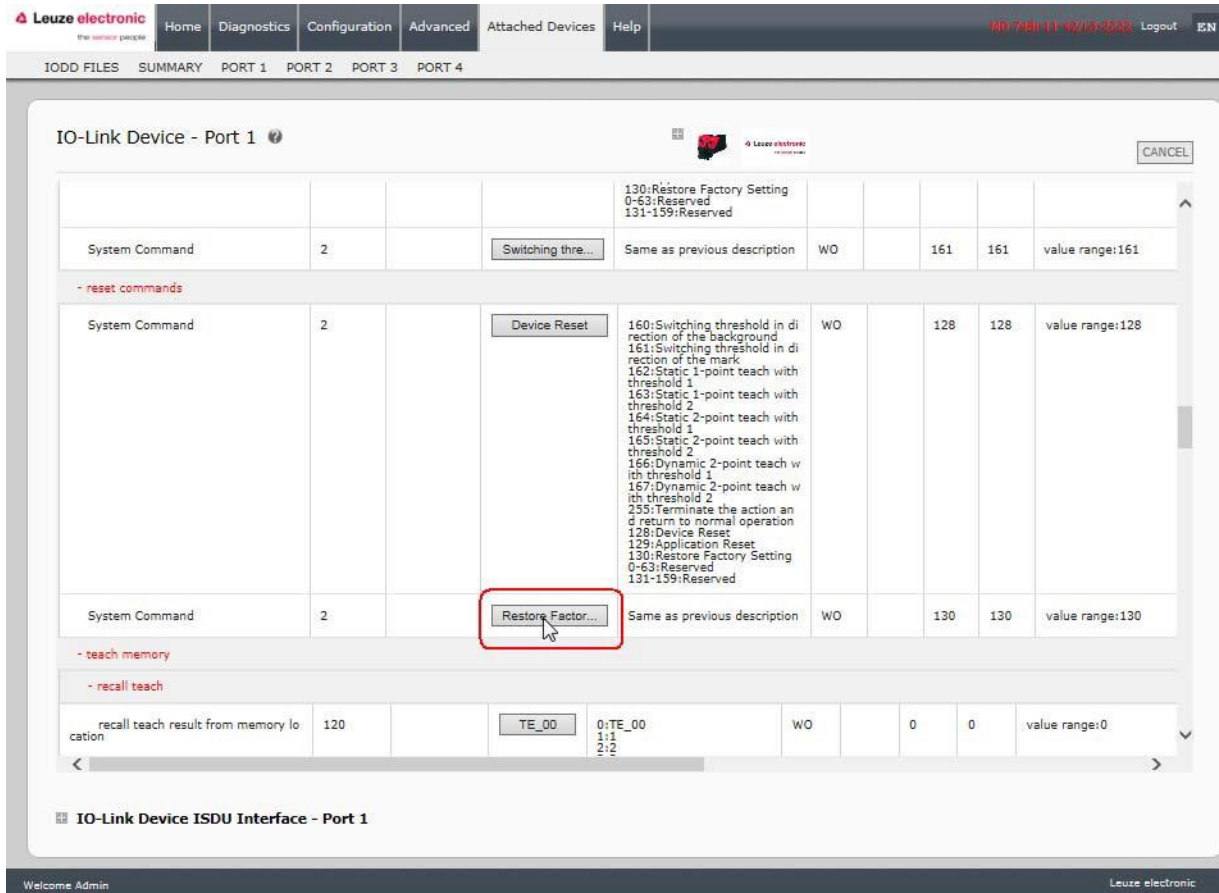

Figure 40: IO-Link device restore factory settings

3. Click **OK** when the Refresh message appears.

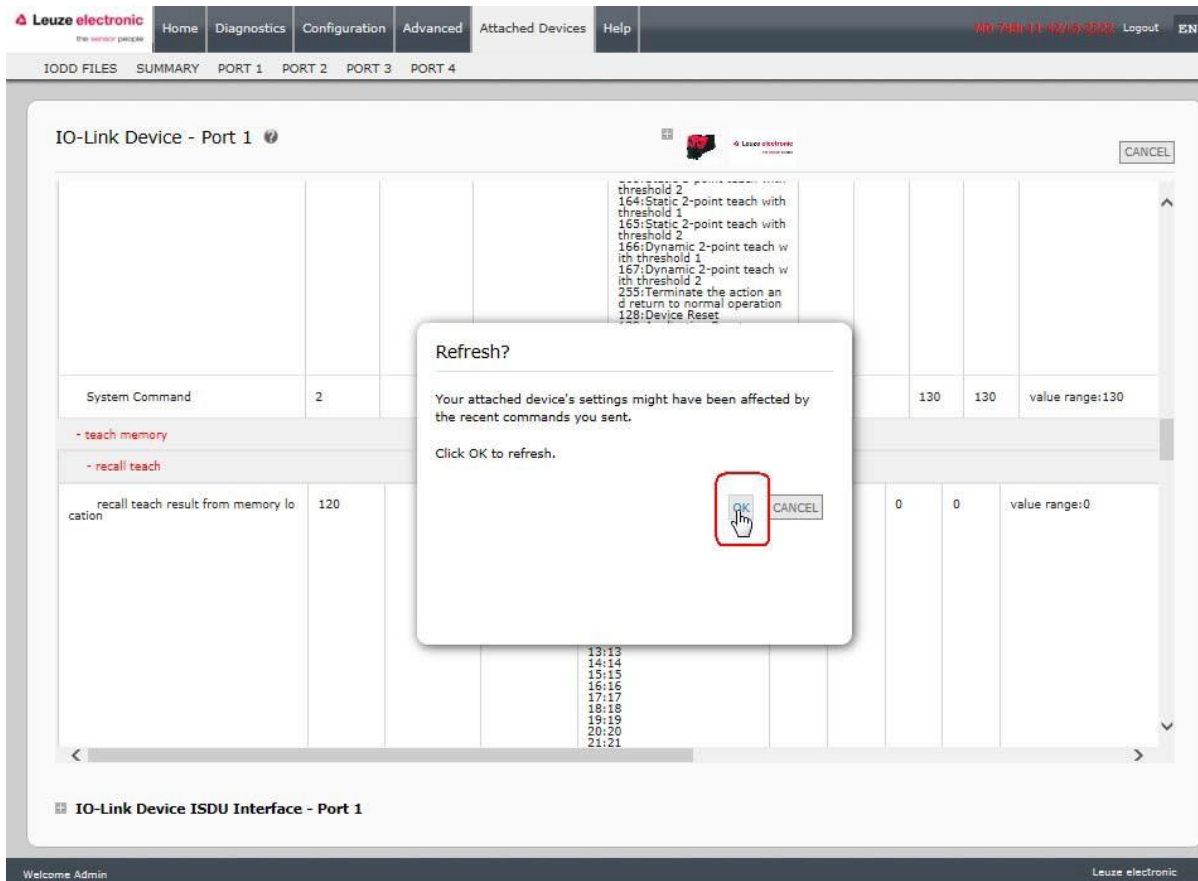

Figure 41: Confirm restore command

### 9.4 Editing Parameters - IO-Link Device ISDU Interface - Port

The **IO-Link Device ISDU Interface** follows these guidelines:

- If necessary, convert hexadecimal ISDU index numbers to decimal, you must enter the decimal value for the ISDU Block Index and ISDU Sub-index numbers.
- You must enter the hexadecimal value for the IO-Link device parameters.

If the appropriate IODD files has been loaded, you can use the **IO-Link Device - Port** table to determine the index numbers and acceptable values for each parameter.

**Note:** An IODD file may not contain every IO-Link device setting depending on the IO-Link device manufacturer. If you need to change a parameter that is not displayed in the **IO-Link Device - Port** table, you can refer to the *IO-Link Device Operators Manual*.

If an IODD file has not been loaded for an IO-Link device, you can use the IO-Link Device Operator's Manual to determine the ISDU indexes.

**Please note:**

- You must enter the decimal value for the ISDU Block Index and ISDU Sub-index.
- The **GET** button retrieves the parameter value in hex from the IO-Link device. You may want to retrieve values to determine the data length.



- The **SET** button sends the value to the IO-Link device.

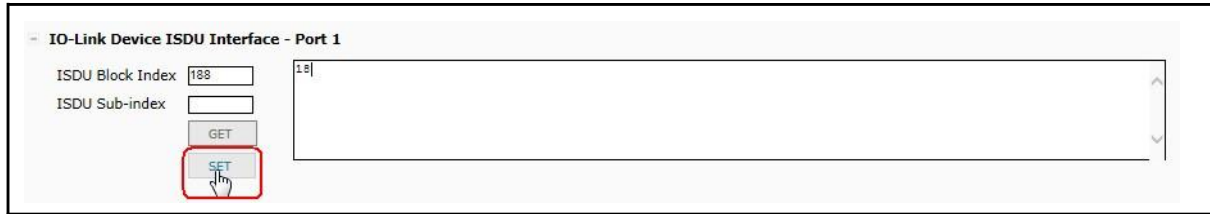

- After successfully changing a parameter, the IO-Link Master responds with a command executed notification.

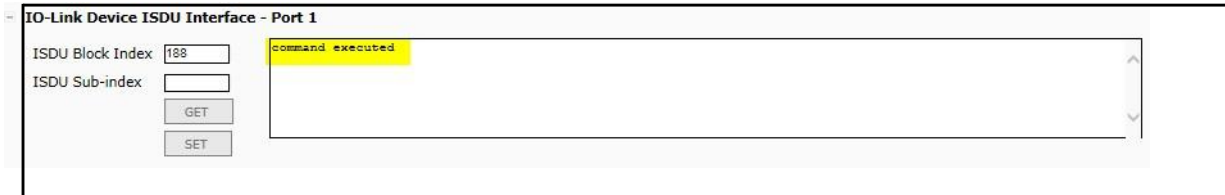

- This message means that the IO-Link device defines the entry as an invalid setting.

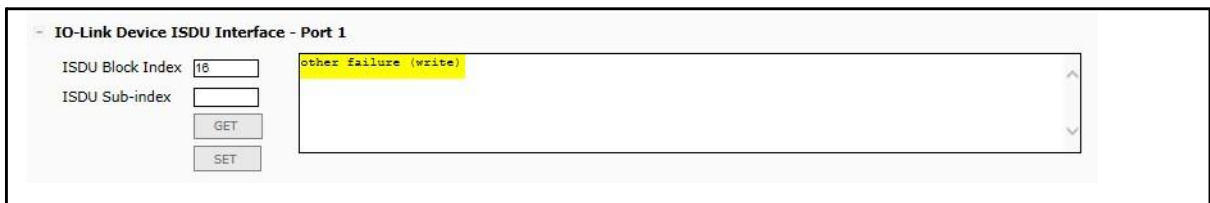

- This message indicates that the IO-Link device cannot read the specified ISDU Block Index and Sub- index.

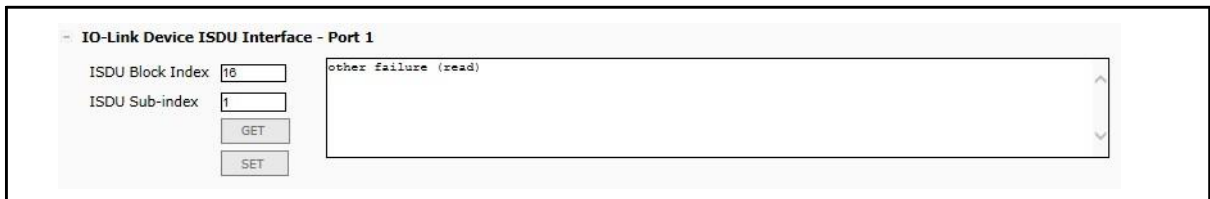

Use the following procedure to edit parameters using the **IO-Link Device ISDU Interface - Port**.

**Note:** You may want to verify that the **Automatic Download Enable for Data Storage** option on the **Configuration / IO-Link Settings** page is **NOT** set to **On** as this can cause unreliable results on the corresponding port.

1. Click the + next to the **IO-Link Device ISDU Interface** to open the interface.

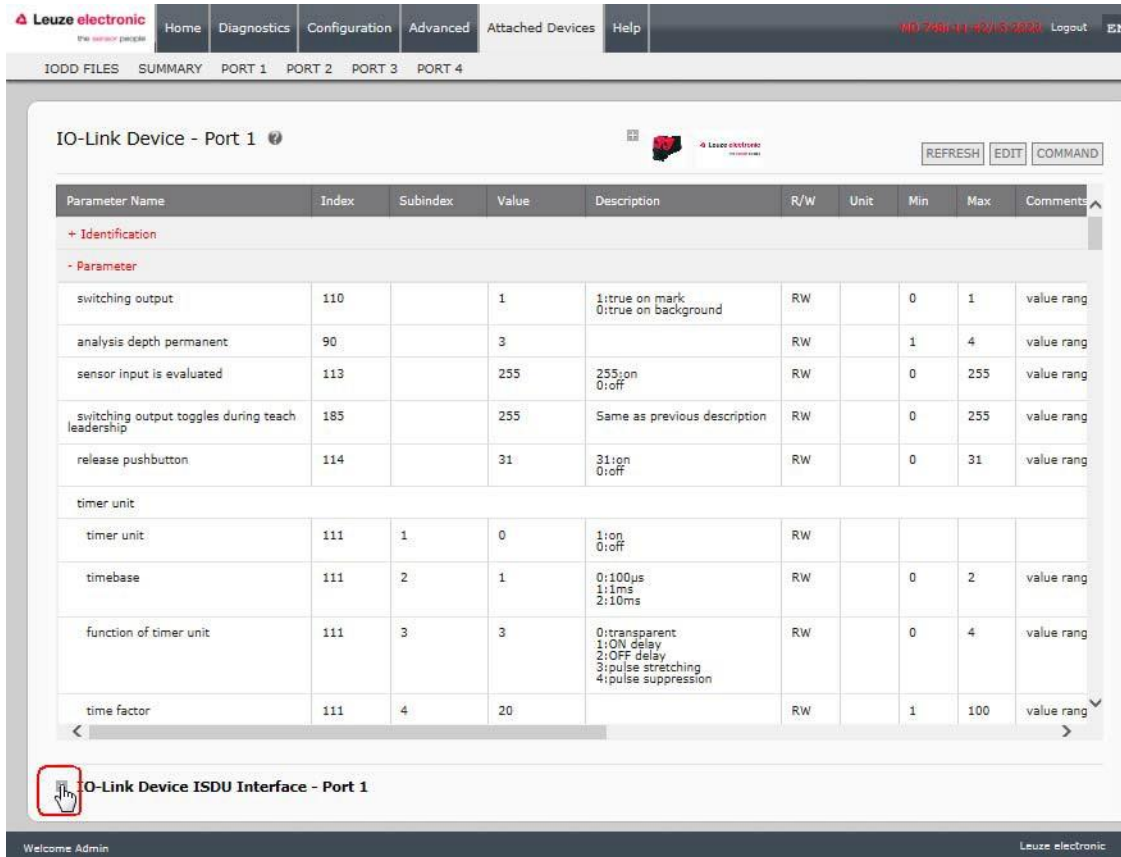

Figure 42: IO-Link iSDU interface

2. Enter the ISDU Block Index number (decimal) that you want to edit.
3. If applicable, enter the ISDU Sub-index (decimal).
4. Edit the parameter (hex) and click the **SET** button.



5. Verify that a *command executed* message returns.
6. If the IODD file is loaded, optionally click **REFRESH** to verify your changes.

The screenshot displays the Leuze electronic web interface for configuring an IO-Link Device on Port 1. The interface includes a navigation menu at the top with options like Home, Diagnostics, Configuration, and Advanced. Below the menu, there are tabs for IODD FILES, SUMMARY, and PORT 1 through PORT 4. The main content area is titled "IO-Link Device - Port 1" and contains a table of threshold levels. The table has columns for parameter names, values, descriptions, and access rights. A yellow highlight is visible on the value "24" in the first row of the threshold levels table. Below the table, there is a section for the "IO-Link Device ISDU Interface - Port 1" which includes input fields for "ISDU Block Index" (set to 188) and "ISDU Sub-index", along with "GET" and "SET" buttons. A text area below these fields shows the message "command executed".

time factor	111	4	20		RW	1	100	value rang
<b>- threshold levels</b>								
position of switching point at ST1P, t each-level 1	188		24	24:very low sensitivity 20:low sensitivity 16:standard sensitivity 12:high sensitivity 8:very high sensitivity	RW	8	24	value rang
position of switching point at ST1P, t each-level 2	189		8	Same as previous description	RW	8	24	value rang
position of switching point at ST2P, t each-level 1	190		50	6:very close to the mark 12:close to the mark 25:toward mark 50:in the middle between the mark and background 70:in direction of the background 82:close to the background 90:very close to the background	RW	6	90	value rang 2;90
position of switching point at ST2P, t each-level 2	191		12	Same as previous description	RW	6	90	value rang 2;90
position of switching point at DT2P, t each-level 1	192		50	Same as previous description	RW	6	90	value rang 2;90

**IO-Link Device ISDU Interface - Port 1**

ISDU Block Index:  command executed

ISDU Sub-index:

Figure 43: IO-Link iSDU feedback

## 10 Utilizing IO-Link Master Features

This chapter discusses using the following features:

- **Data Storage** (automatic and manual) to upload or download IO-Link v1.1 device parameters
- **Device Validation** (identical or compatible) to dedicate a port or ports to specific IO-Link devices
- **Data Validation** (strict or loose) to verify data integrity
- **Menu Bar Hover Shows Submenu**, which provides an option to navigate the submenu structure quickly.

**Note:** You must configure data storage, device validation, data validation in PROFINET IO using Step 7. You can use data storage on the web page for temporary data storage related tasks.

### 10.1 Data Storage

Data storage is typically supported by IO-Link v1.1 devices. *Data storage* means that you can upload parameters from an IO-Link device to the IO-Link Master and/or download parameters from the IO-Link Master to the IO-Link device. This feature can be used to:

- Quickly and easily replace a defective IO-Link device
- Configure multiple IO-Link devices with the same parameters as fast as it takes to connect and disconnect the IO-Link device

To determine whether an IO-Link (v1.1) device supports data storage, you can check one of the following:

- **IO-Link Diagnostics** page - check the **Data Storage Capable** field to see if it displays **Yes**.
- **IO-Link Configuration** page - check to see if **UPLOAD** and **DOWNLOAD** buttons display under the **Data Storage Manual Ops** group. If only a **Clear** button displays, the device on the port does not support data storage.

#### 10.1.1 Uploading Data Storage to the IO-Link Master

The IO-Link device manufacturer determines which parameters are saved for data storage. Remember, the IO-Link device should be configured before enabling data storage unless you are using data storage to back up the default device configuration.

There are two methods to upload Data Storage using the **Configuration | IO-Link** page:

- **Automatic Enable Upload** - If a port is set to **On** for this option, the IO-Link Master saves the data storage (if the data storage is empty) from the IO-Link device to that port. Some IO-Link devices update the data storage contents if you use the Teach buttons on the IO-Link device, but that is determined by the IO-Link device manufacturer.

When this option is enabled and another IO-Link device (different Vendor ID and Device ID), the **IO-Link Diagnostics** page displays a *DV: Wrong Sensor* in the **IOLink State** field and the IO-Link port LED flashes red, indicating a hardware fault.

Automatic upload occurs when the **Automatic Upload Enable** option is set to **On** and one of these conditions exists:

- There is no upload data stored on the gateway.
- The IO-Link device executes a **requests\_ at upload** function (generally because you have changed the configuration via Teach buttons).

You should not enable **Automatic Upload** until after you have configured the IO-Link device attached to the port unless you want to capture the default settings.

**Note:** Do not enable both **Automatic Upload** and **Download** at the same time, the results are not reliable among IO-Link device manufacturers.

- **Data Storage Manual Ops: UPLOAD** - Selecting the **UPLOAD** button saves the data storage from the IO-Link device to that port. The content of the data storage does not change unless it is uploaded again or cleared. Another IO-Link device with a different Vendor ID and Device ID can be attached to the port without causing a hardware fault.

### 10.1.2 Downloading Data Storage to the IO-Link Device

There are two methods to download Data Storage using the **Configuration | IO-Link Device** page:

- **Automatic Download Enable** - An automatic download occurs when the Automatic Download Enable option is set to On and one of these conditions exists:
  - The original IO-Link device is disconnected and an IO-Link device who's configuration data differs from the stored configuration data.
  - The IO-Link device requests an upload and the **Automatic Upload Enable** option is set to **Off**.

**Note:** Do not enable both Automatic Upload and Download at the same time, the results are not reliable among IO-Link device manufacturers.

- **Data Storage Manual Ops: DOWNLOAD** - Selecting the **DOWNLOAD** button downloads the data storage from the port to the IO-Link device.

If an IO-Link device with a different Vendor ID and Device ID is attached to the port and a manual download is attempted, the IO-Link Master issues a hardware fault.

### 10.1.3 Automatic Device Configuration

Use the following steps to use an IO-Link Master port to configure multiple IO-Link devices with the same configuration parameters.

1. If necessary, configure the IO-Link device as required for the environment.
2. Click **Configuration| IO-Link**.
3. Click the **EDIT** button for the port for which you want to store the data on the IO-Link Master.
4. Click the **UPLOAD** button.

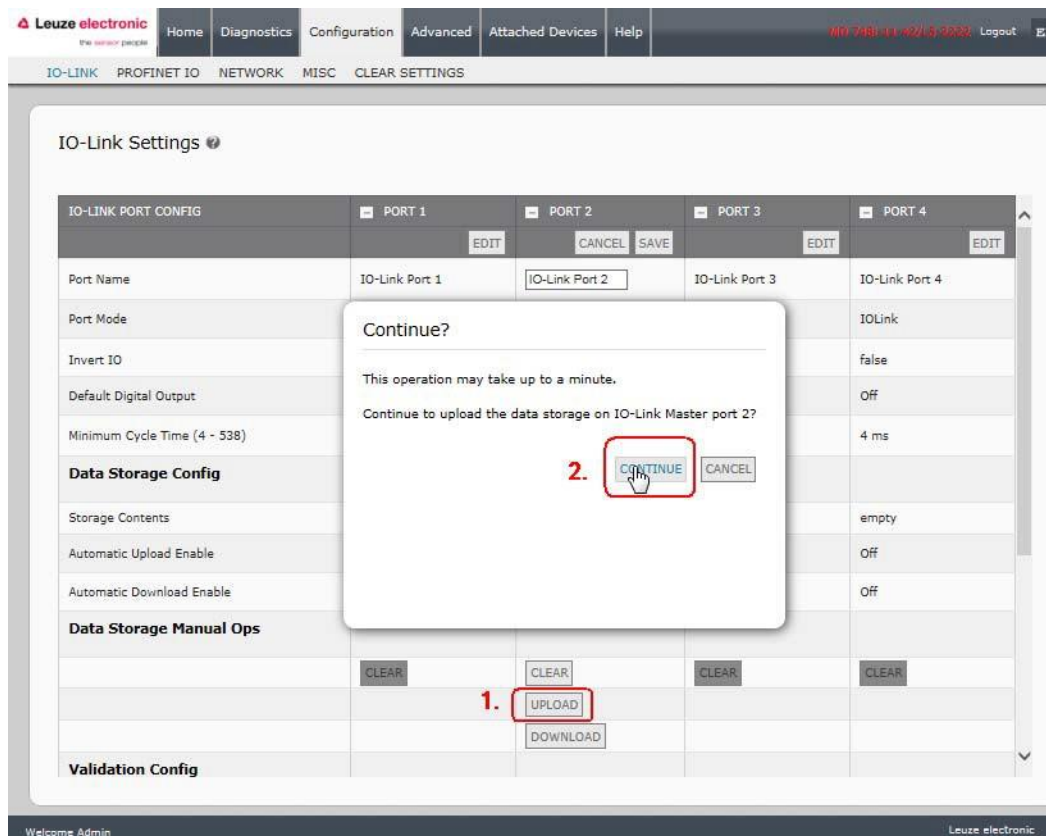

Figure 44: Data storage upload

5. Click the **CONTINUE** button to the Continue to upload the data storage on IO-Link Master port [number] message.
6. Click the **Ok** button to the *Data storage upload successful on Port [number]* message.

7. Set the **Automatic Download Enable** option to **On**.

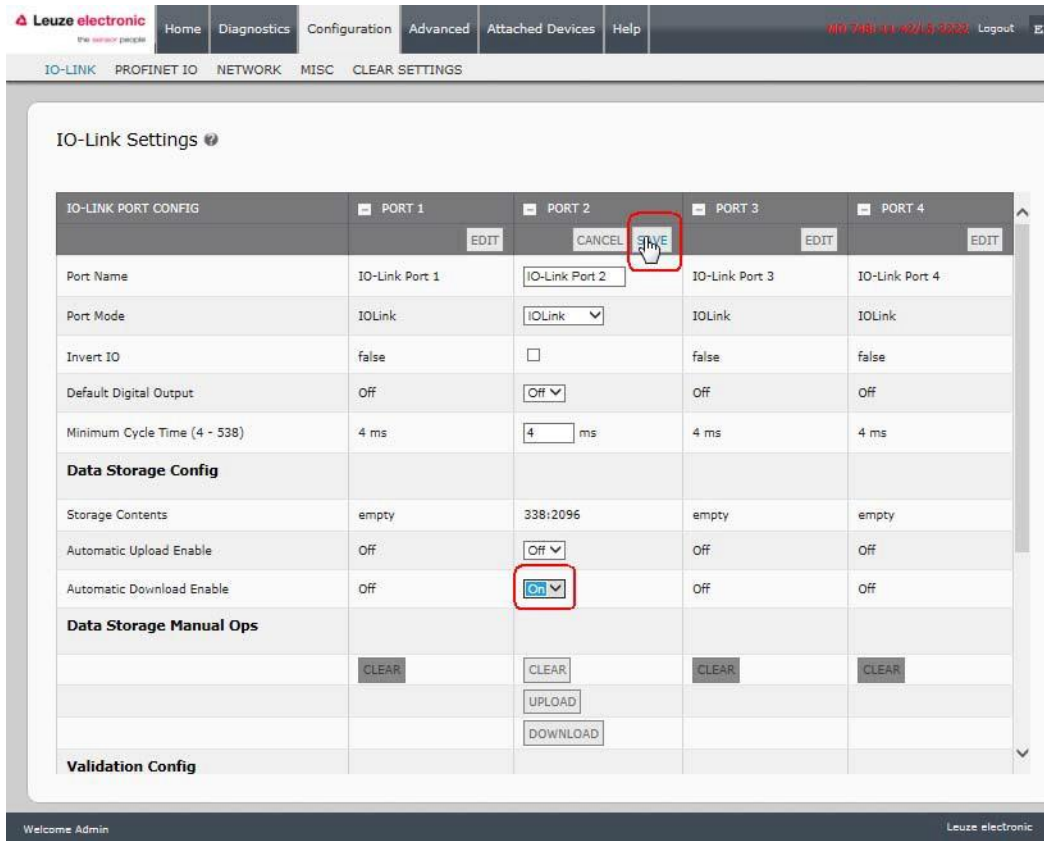

Figure 45: Data storage configuration

8. Click **SAVE**.
9. Click **Diagnostics | IO-Link**.
10. Replace the IO-Link device on that port with the IO-Link device for which you want configured automatically.
11. Verify that the IO-Link device displays operational **Port Status** and the appropriate IO-Link State.
12. Repeat Steps 10 and 11 for as many device as you want to configure.

### 10.1.4 Automatic Device Configuration Backup

The following procedure shows how to utilize data storage to automatically backup an IO-Link device configuration.

Remember, if you adjust parameters using **Teach** buttons those values may or not may be updated in the data storage, which depends on the IO-Link device manufacturer. If you are unsure, you can always use the manual **UPLOAD** feature to capture the latest settings.

1. Click **Configuration | IO-Link**.
2. Click the **EDIT** button for the port for which you want to store the data on the IO-Link Master.
3. Select **On** in the drop list for **Automatic Data Storage Upload Enable**.

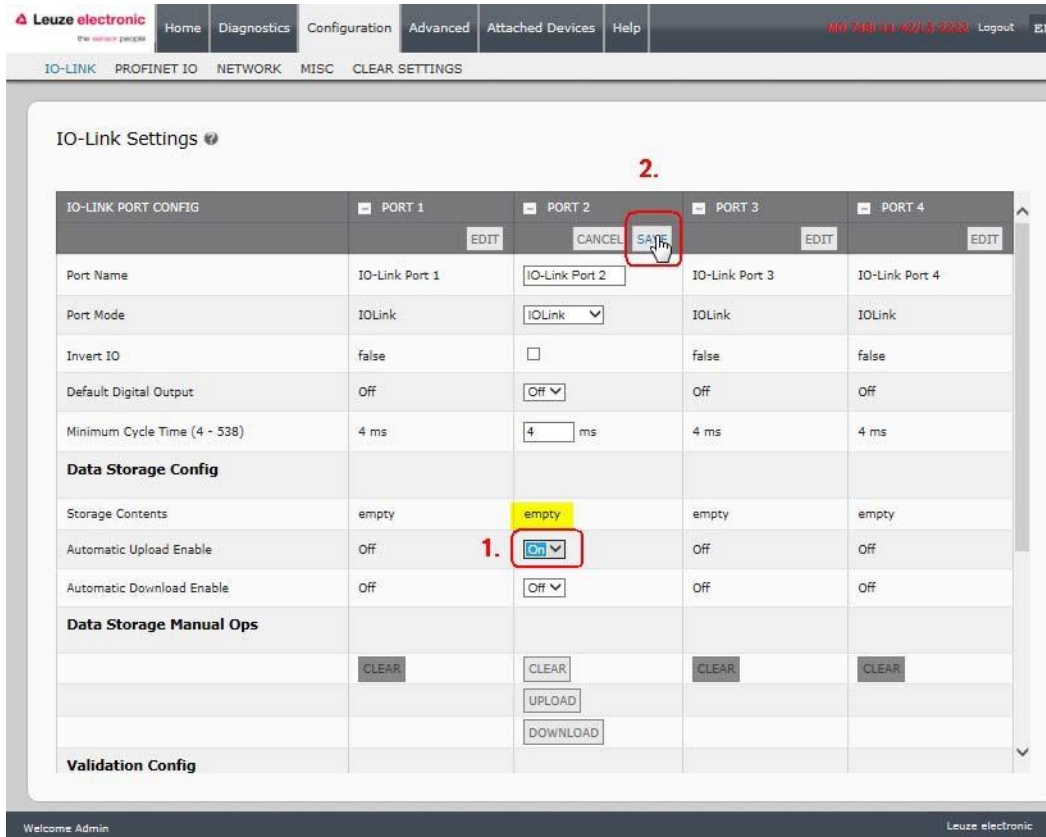

Figure 46: Activate automatic data storage upload

4. Click **SAVE**.

When the **Configuration | IO-Link** page is refreshed, the **Storage Contents** field displays the **Vendor ID** and **Device ID**. In addition, the **IO-Link Diagnostics** page displays **Upload-Only** in the **Automatic Data Storage Configuration** field.

## 10.2 Device Validation

Device validation is supported by many IO-Link devices. **Device Validation Mode** provides these options:

- **None** - this disables **Device Validation Mode**.
- **Compatible** - permits a compatible IO-Link device (same Vendor ID and Device ID) to function on the corresponding port.
- **Identical** - only permits an IO-Link device (same Vendor ID, Device ID, and serial number) to function on the corresponding port.

Use this procedure to configure device validation.

1. Click **Configuration | IO-Link Settings**.
2. Click the **EDIT** button.

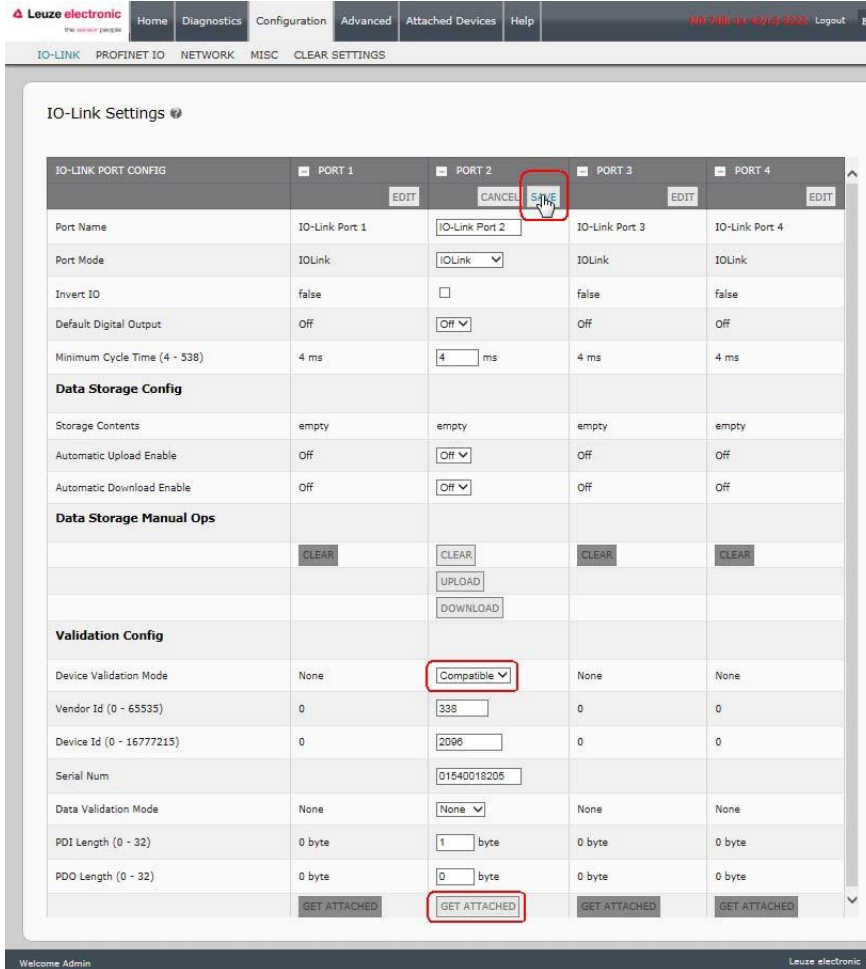

Figure 47: IO-Link device validation settings

3. Select **Compatible** or **Identical** for the **Device Validation** mode.  
*Note: Identical Device Validation requires a device serial number to operate.*
4. Click the **GET ATTACHED** button or manually complete the Vendor ID, Device, ID, and serial number.  
 If the device does not have a serial number, you should not select **Identical** because the IO-Link Master requires a serial number to identify a specific device.
5. Click the **SAVE** button. If the wrong or incompatible device is connected to the port, the IO-Link port LED flashes red and no IO-Link activity occurs on the port until the issue is resolved. In addition, the **IO-Link Diagnostics** page displays the following information.

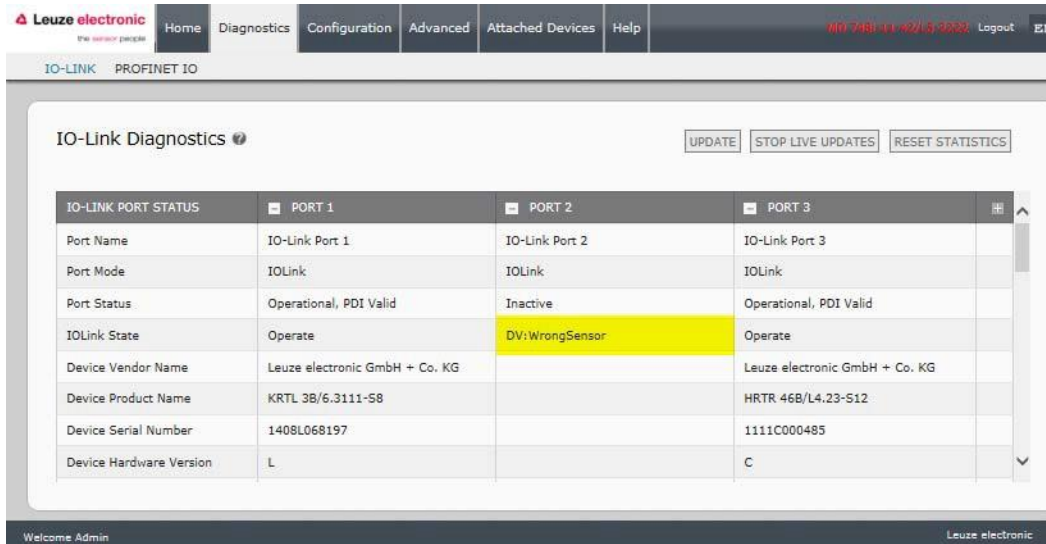

Figure 48: IO-Link device validation

### 10.3 Data Validation

You can use this procedure to configure data validation.

1. Click **Configuration | IO-Link Settings**.
2. Click the **EDIT** button on the port you want to configure for data validation.
3. Select **Loose** or **Strict** to enable data validation.
  - **Loose** - the slave device's PDI/PDO lengths must be less than or equal to the user-configured values.
  - **Strict** - the slave device's PDI/PDO lengths must be the same as the user-configured values.
4. Click the **GET ATTACHED** button or manually enter the PDI and PDO length.

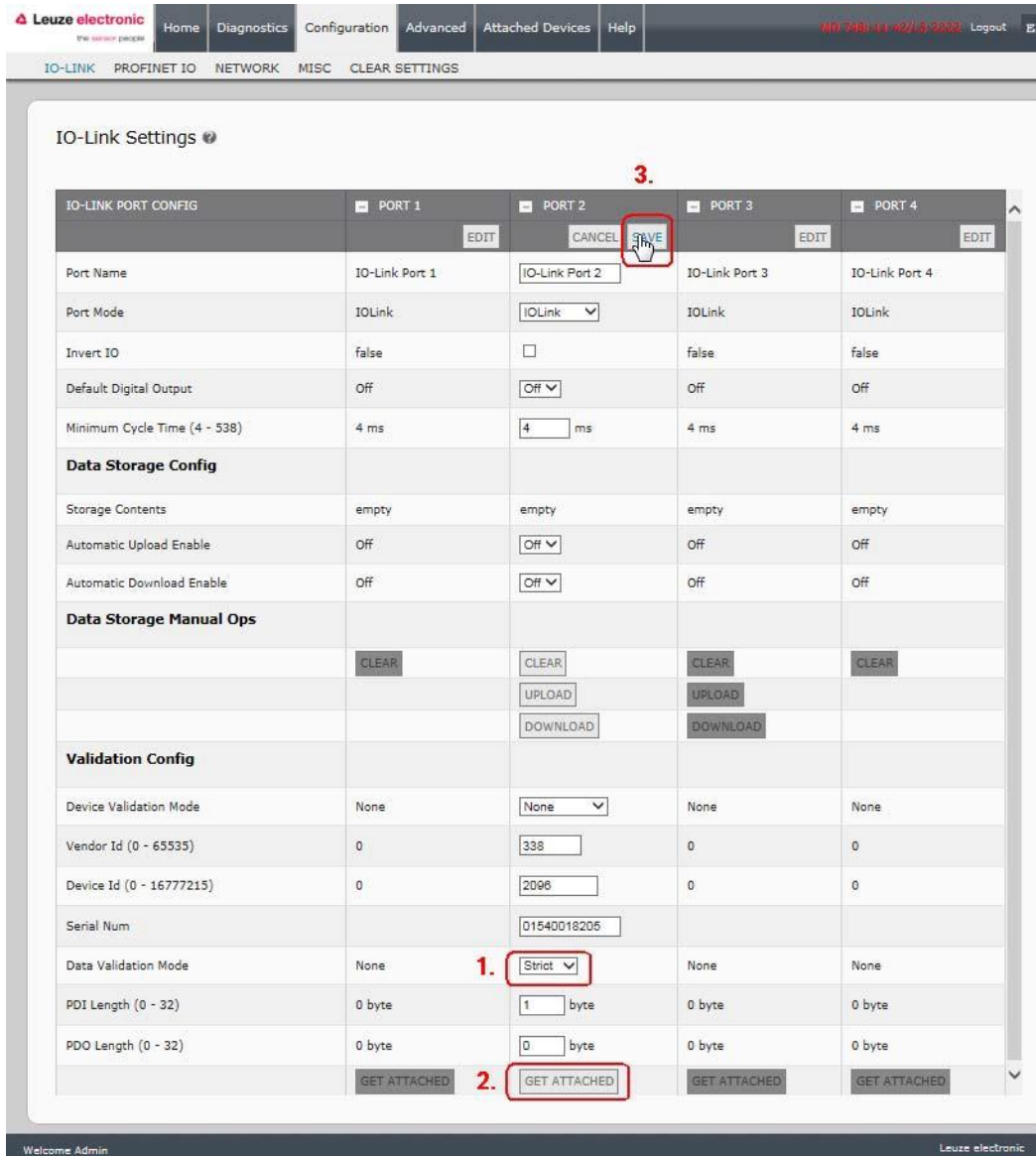

Figure 49: Upload device data for validation

5. Click the **SAVE** button.

If data validation fails, the IO-Link port LED flashes red and the **IO-Link Diagnostics** page displays an error.

### 10.4 Using the Menu Bar Hover Shows Submenu Option

Use this procedure to enable the **Menu Bar Hover Shows Submenu** option. If you enable this feature it displays the submenus for a category when you hover over the category name.

For example, if you hover over **Advanced**, the **SOFTWARE, ACCOUNTS, LOG FILES, and LICENSES** submenus display. You can click any submenu and avoid opening the default menu for a category.

1. Click **Configuration | MISC**.
2. Click the **EDIT** button.
3. Click **Enable** next to the **Menu Bar Hover Shows Submenu** option.
4. Click **SAVE**.

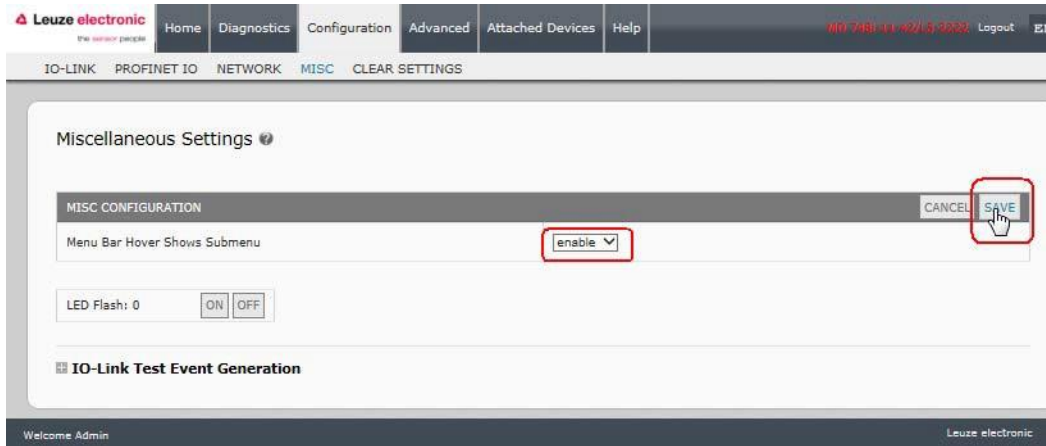

### 10.5 IO-Link Test Event Generator

You can use the **IO-Link Test Event Generator** to send messages through the IO-Link Master. The generated events are displayed in the **Diagnostics | IO-Link Settings** page under the **Last Events** field and the syslog.

IO-Link Test Event Generator Descriptions	
Port	The port number to which you want to send an event.
Mode	This is the first item in the event generated. <ul style="list-style-type: none"> <li>• <b>Single</b>: generates <b>Single</b> in the event.</li> <li>• <b>Coming</b>: generates <b>Active</b> in the event</li> <li>• <b>Going</b>: generates <b>Cleared</b> in the event</li> </ul>
Type	This is the second item in the event generated. <ul style="list-style-type: none"> <li>• <b>Message</b>: generates <b>Message</b> in the event.</li> <li>• <b>Warning</b>: generates <b>Warning</b> in the event.</li> <li>• <b>Error</b>: generates <b>Error</b> in the event.</li> </ul>
Instance	This is the level in which the event is generated. This is not displayed in the generated event. <ul style="list-style-type: none"> <li>• <b>unknown</b></li> <li>• <b>physical</b></li> <li>• <b>datalink</b></li> <li>• <b>applayer</b></li> <li>• <b>application</b></li> </ul>
Source	This is the source in which the event is generated. This is the third item in the generated event. <ul style="list-style-type: none"> <li>• <b>local</b>: simulation generated from the IO-Link Master, which displays as <b>Local</b> in the event.</li> <li>• <b>remote</b>: simulation of an IO-Link device event, which displays as <b>Device</b> in the generated event.</li> </ul>
PDI	This indicates whether to send valid or invalid PDI, which is not displayed in the generated event. <ul style="list-style-type: none"> <li>• <b>valid</b></li> <li>• <b>invalid</b></li> </ul>

<b>IO-Link Test Event Generator Descriptions</b>	
Code	<p>This is the fourth and fifth items in the generated event.</p> <ul style="list-style-type: none"> <li>• 0x0000: generates a <b>s_pdu_check</b> event</li> <li>• 0x0001: generates a <b>s_pdu_flow</b> event</li> <li>• 0x0002: generates a <b>m_pdu_check</b> event</li> <li>• 0x0003: generates a <b>s_pdu_illegal</b> event</li> <li>• 0x0004: generates a <b>m_pdu_illegal</b> event</li> <li>• 0x0005: generates a <b>s_pdu_buffer</b> event</li> <li>• 0x0006: generates a <b>s_pdu_inkr</b> event</li> <li>• 0x0007: generates an <b>s_pd_len</b> event</li> <li>• 0x0008: generates an <b>s_no_pdin</b> event</li> <li>• 0x0009: generates an <b>s_no_pdout</b> event</li> <li>• 0x000a: generates an <b>s_channel</b> event</li> <li>• 0x000b: generates an <b>m_event</b> event</li> <li>• 0x000c: generates an <b>a_message</b> event</li> <li>• 0x000d: generates an <b>a_warning</b> event</li> <li>• 0x000e: generates an <b>a_device</b> event</li> <li>• 0x000f: generates an <b>a_parameter</b> event</li> <li>• 0x0010: generates a <b>devicelost</b> event</li> <li>• 0x0011, 13 - 17: generates an unknown event</li> <li>• 0x0012: generates a <b>s_desina</b> event</li> </ul>

## 11 Using the Diagnostics Pages

This chapter provides information about the following Diagnostics pages.

- *IO-Link Port Diagnostics*
- *Digital I/O Diagnostics*
- *PROFINET IO Diagnostics Page*

### 11.1 IO-Link Port Diagnostics

Use the **IO-Link Diagnostics** page to determine the status of the IO-Link configuration.

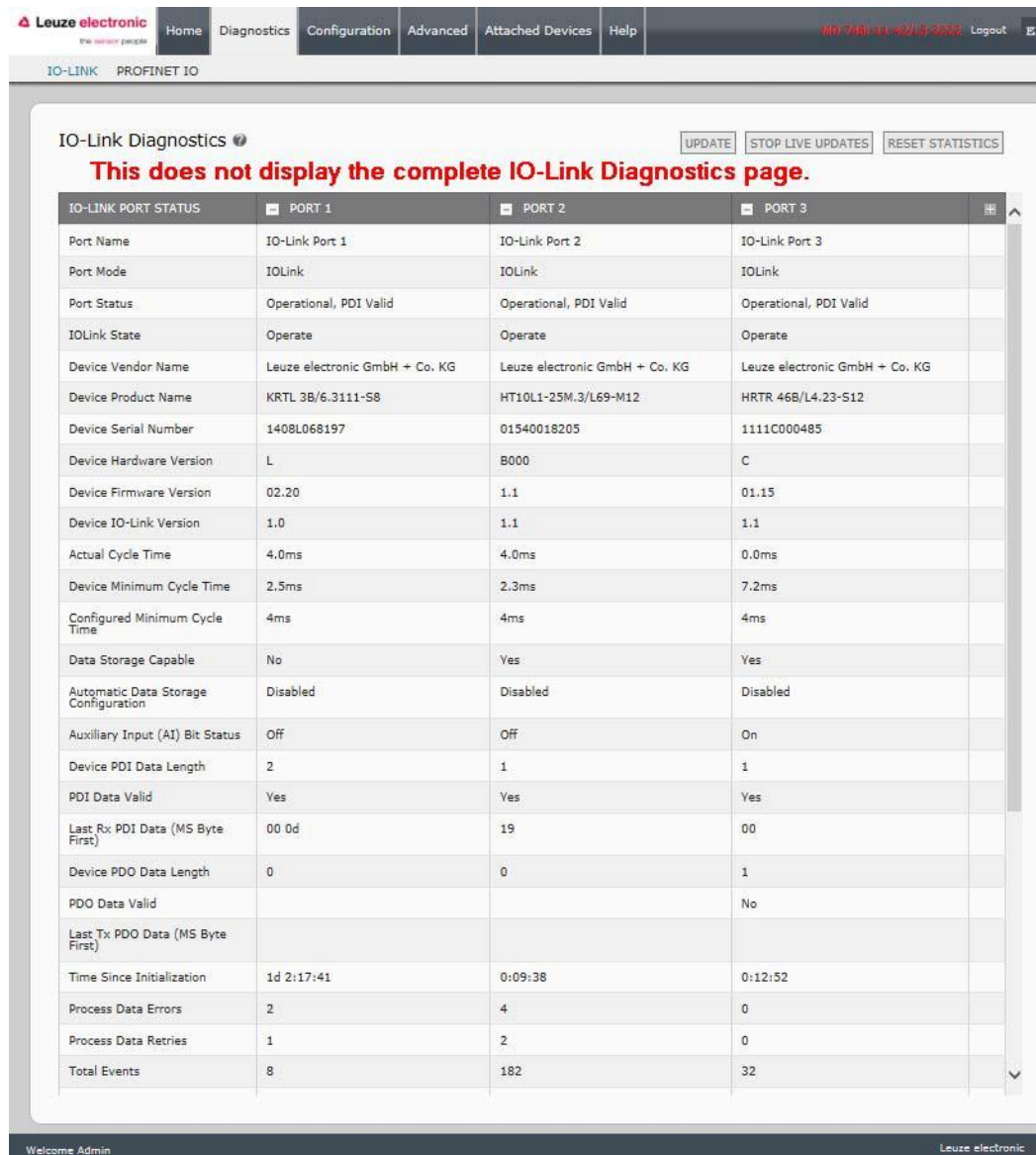

Figure 50: IO-Link diagnostic page

The following table provides information about the **IO-Link Diagnostics** page.

IO-Link Diagnostics	
Port Name	This is an optional friendly port name, which can be configured in the <b>Configuration   IO-Link</b> page.
Port Mode	Displays the active device mode: <ul style="list-style-type: none"> <li>• <b>Reset</b> = The port is configured to disable all functionality.</li> <li>• <b>IO-Link</b> = The port is configured to IO-Link mode.</li> <li>• <b>Digital In</b> = The port is configured to operate as a digital input.</li> <li>• <b>Digital Out</b> = The port is configured to operate as a digital output.</li> </ul>
Port Status	Displays the port status: <ul style="list-style-type: none"> <li>• <b>Inactive</b> = The port is in active state. Typically, this indicates that the device is either not attached or not detected.</li> <li>• <b>Initializing</b> = The port is in the process of initializing.</li> <li>• <b>Operational</b> = The port is operational and, if in IO-Link mode, communications to the IO-Link device has been established.</li> <li>• <b>PDI Valid</b> = The PDI data is now valid.</li> <li>• <b>Fault</b> = The port has detected a fault and is unable to re-establish communications.</li> </ul>
IO-Link State	<ul style="list-style-type: none"> <li>• <b>Operate</b> - Port is functioning correctly in IO-Link mode but has not received valid PDI data. This may also display during a data storage upload or download.</li> <li>• <b>Init</b> - The port is attempting initialization.</li> <li>• <b>Reset</b> - One of the following conditions exists:               <ul style="list-style-type: none"> <li>• The Port Mode configuration is set to <b>Reset</b>.</li> <li>• The Port Mode configuration is set to <b>DigitalIn</b> or <b>DigitalOut</b>.</li> </ul> </li> <li>• <b>DS - Wrong Sensor</b> - Hardware failure (IO-Link LED also flashes red) because there is Data Storage on this port, which does not reflect the attached device.</li> <li>• <b>DV - Wrong Sensor</b> - Hardware failure (IO-Link LED also flashes red) because Device Validation is configured for this port and the wrong device is attached.</li> <li>• <b>DS - Wrong Size</b> - Hardware failure (IO-Link LED also flashes red) because the size of the configuration on the device does not match the size of the configuration stored on the port.</li> <li>• <b>Comm Lost</b> - Temporary state after a device is disconnected and before the port is re-initialized.</li> <li>• <b>Pre-operate</b> - Temporary status displayed when the device:               <ul style="list-style-type: none"> <li>• Is starting up after connection or power-up.</li> <li>• Uploading or downloading automatic data storage.</li> </ul> </li> </ul>
Device Vendor Name	Displays the Device Vendor Name as stored in ISDU Index 16.
Device Product Name	Displays the device product name as stored in ISDU Index 18.
Device Serial Number	Displays the device serial number as stored in ISDU Index 21.
Device Hardware Version	Displays the device hardware version as stored in ISDU Index 22.
Device Firmware Version	Displays the device firmware version as stored in ISDU Index 23.
Device IO-Link Version	The supported device IO-Link version as stored in ISDU Index 0.

<b>IO-Link Diagnostics</b>	
Actual Cycle Time	This is the actual, or current, cycle time of the IO-Link connection to the device.
Device Minimum Cycle Time	This is the minimum, or fastest, cycle time supported by the connected IO-Link device.
Configured Minimum Cycle Time	Configured in the <b>Configuration   IO-Link</b> page, this is the minimum cycle time the IO-Link Master will allow the port to operate at. The <b>Actual Cycle Time</b> , which is negotiated between the IO-Link Master and the device, will be at least as long as the greater of the <b>Configured Minimum Cycle Time</b> and the <b>Device Minimum Cycle Time</b> .
Data Storage Capable	Displays whether the IO-Link device on a port supports the data storage feature. Not all IO-Link devices support the data storage feature.
Automatic Data Storage Configuration	Displays whether a port is configured to automatically upload data from the IO-Link device or download data from the IO-Link Master to the IO-Link device. Disabled displays if automatic upload or download are not enabled.
Auxiliary Input (AI) Bit Status	The current status of the auxiliary bit as received on DI (Pin 2 on the MD 748I-11-42/L5-2222) of the IO-Link port.
Device PDI Data Length	The supported Device PDI Data Length, in bytes, as stored in ISDU Index 0.
PDI Data Valid	Current status of PDI data as received from the IO-Link device.
Last Rx PDI Data (MS Byte First)	The last Rx PDI data as received from the IO-Link device.
Device PDO Data Length	The supported Device PDO Data Length, in bytes, as stored in ISDU Index 0.
PDO Data Valid	Status of PDO data being received from controller(s).
Last Tx PDO Data (MS Byte First)	The last Tx PDO data.
Time Since Initialization	The time since the last port initialization.
Process Data Errors	The number of process data errors the port received.
Process Data Retries	The number of process data retries the port performed.
Total Events	The total number of events that were received on this port.
First Events	Up to the first, or oldest, three events that were received on this port.
Last Events	Up to the last, or most recent, three events that were received on this port.
<b>ISDU Statistics</b>	
ISDU Read Cmd Attempts	The number of read ISDU command attempts.
ISDU Read Cmd Errors	The number of read ISDU command errors.
ISDU Write Cmd Attempts	The number of write ISDU command attempts.
ISDU Write Cmd Errors	The number of write ISDU command errors.

## 11.2 Digital I/O Diagnostics

The **Digital I/O Diagnostics** page may be useful when trying to troubleshoot port issues related to configuration.

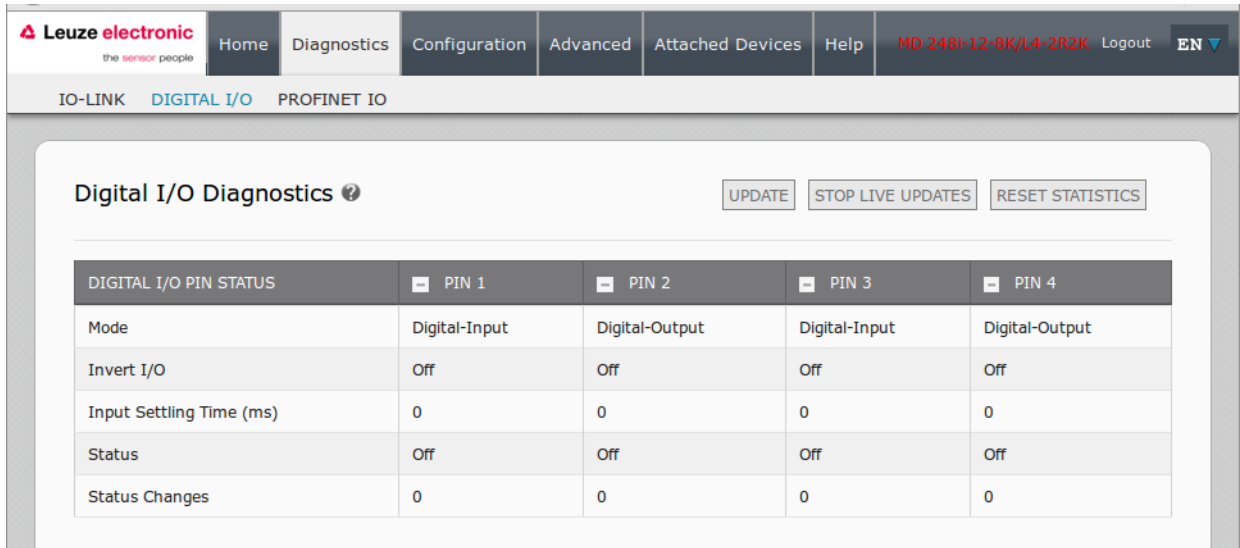

Figure 51: Digital I/O diagnostic page

The following table provides information about the Digital I/O Diagnostics page.

Digital I/O Diagnostics	
Mode	Displays the current configured operating mode of the digital I/O pin. <ul style="list-style-type: none"> <li>• <b>Off</b></li> <li>• <b>Digital-Input</b></li> <li>• <b>Digital-Output</b> (Pins D2 and D4 only)</li> </ul>
Invert I/O	Displays the current configured Invert I/O setting: <ul style="list-style-type: none"> <li>• <b>On</b> (Invert I/O)</li> <li>• <b>Off</b> (Do not invert I/O)</li> </ul>
Input Settling Time (ms)	Displays the current configured input settling time.
Status	Displays the current status of the digital I/O pin. <ul style="list-style-type: none"> <li>• <b>On</b> (high voltage)</li> <li>• <b>Off</b> (low voltage)</li> </ul>
Status Changes	Displays the number of times that the status of the digital I/O pin has changed.

### 11.3 PROFINET IO Diagnostics Page

The **PROFINET IO Diagnostics** page may be useful when trying to troubleshoot communications or port issues related to PROFINET IO configuration.

PROFINET IO Diagnostics

UPDATE STOP LIVE UPDATES RESET STATISTICS

PROFINET IO GENERAL STATUS	
Active Application Relationships	0
Application Relationship 1 Uptime	
Application Relationship 2 Uptime	
Total Application Relationships Established	0
IDL_CALL Function Block Requests	0
IDL_CALL Function Block Errors	0
Configuration Errors	0
System Errors	0
PROFINET IO Frames Transmitted	21734
PROFINET IO Transmit Errors	0
PROFINET IO Frames Received	60042
PROFINET IO Receive Errors	0
Record Reads	0
Record Read Errors	0
IP Assignment	Static
Ethernet Port 1 Link Status	100Mbps Full Duplex
Ethernet Port 2 Link Status	Link Down
First Error String	No Error Detected
Last Error String	

**This image does not display the complete PROFINET IO Diagnostics page.**

PROFINET IO PORT STATUS	PORT 1	PORT 2	PORT 3	PORT 4
Application Relationship				
PDI Reads	0	0	0	0
PDI Reads Truncated	0	0	0	0
PDI Read Errors	0	0	0	0
PDO Writes	0	0	0	0
PDO Write Errors	0	0	0	0
Event Reads	0	0	0	0

Welcome Admin Leuze electronic

Figure 52: PROFINET IO diagnostic page

## 12 PROFINET IO Reference Information

### 12.1 Sample IO-Link Master Gateway Configuration

This section demonstrates how to configure and use an IO-Link gateway.

Slot	Module	Order number	I address	Q address	Diagnostic address:	Com...	Access
0	<b>MD248i</b>	<b>50131483</b>			<b>2042*</b>		<b>Full</b>
X1	Interface				2041*		Full
X1 P1	Port 1				2040*		Full
X1 P2	Port 2				2039*		Full
1	IO-Link In 2 bytes		5...6				Full
2	IO-Link In/Out 2 bytes		7...8	1...2			Full
3	SIO Digital In		9				Full
4	SIO Digital Out			3			Full
5							
6							
7							
8							
9	IO-Link Status		0...3				Full
10	Digital I/O		4	0			Full
11							

Figure 53: IO-Link Master Gateway Configuration

- The first IO-Link device, which supported 2 bytes of PDI data, was connected to IO-Link Port 1. The PDI data were mapped into the process image at address IW 5 of the IO controller, as shown in the figure above. The IO controller could read the current PDI data from the IO-Link device at IW 5.
- The second IO-Link device, which supported 2 bytes of PDI data and 2 bytes of PDO data, was connected to IO-Link Port 2. The PDI data were mapped into the process image at address IW 7. The PDO data were mapped into process image at address QW 2. The IO controller could access PDI and PDO via the two memory locations.
- IO-Link Port 3 and Port 4 were configured as SIO Digital In and SIO Digital Out. The IO controller could read the input status of the C/Q pin of Port 3 at IB 9, and set the output C/Q pin value of Port 4 by writing to QB 3. IO-Link port status was reported through the module in Slot 9. The 4-byte port status was available at IB 0 to IB 3.
- A Digital I/O module was plugged in Slot 10. DIO 2 and 4 were configured as digital outputs. The IO controller could read digital input status at IB 4 and set digital output at QB 0.

Using a variable table, as shown in the following, we monitored and modified the IO data directly.

	Address	Symbol	Display format	Status value	Modify value
1	IB 0	"Status_Active"	BIN	2#0000_1111	
2	IB 1	"Status_PDValid"	BIN	2#0000_0111	
3	IB 2	"Status_AuxiliaryInput"	BIN	2#0000_1111	
4	IB 3	"Status_Error"	BIN	2#0000_0000	
5	IW 5	"P1_IOLinkIn2bytes"	HEX	W#16#090E	
6	IW 7	"P2_IOLinkIn2bytes"	HEX	W#16#03F6	
7	QW 1	"P2_IOLinkOut2bytes"	HEX	W#16#0000	
8	IB 9	"P3_SIOInput"	HEX	B#16#01	
9	QB 3	"P4_SIOOutput"	HEX	B#16#01	B#16#01
10	IB 4	"DIO_Input"	BIN	2#0000_1111	
11	QB 0	"DIO_Output"	BIN	2#0000_1010	2#0000_1010

Figure 54: Monitor and Modify IO Data via Variable Table

IB 0-3 were input data from IO-Link Status module (Slot 9). IB 0 was IO-Link Active, IB 1 was PDI Valid, IB 2 was Auxiliary Input, and IB 3 was IO-Link Error. According to the current value of IB 0, Ports 1-4 were active. IB 1 showed the PDI data of Ports 1-3 were valid. Port 4 was an output module therefore; the PDI valid bit was zero. IB 2 showed that the auxiliary input pins of Port 1-4 were high. No errors were detected so IB 3 was zero.

The PDI data of Port 1 was 0x090E (IW 5). The PDI data of Port 2 was 0x03F6 (IW 7).

In this example, we used wires to connect the C/Q pin and auxiliary input pin of Port 3 and Port 4 together, creating a testing loopback. Then we changed QB 3 to 0x01, which set the C/Q Pin of Port 4 and both auxiliary input pins of Port 3 and 4 to high. IB 9 showed the status of the C/Q pin of Port 3 was high (0x01). The high status of auxiliary input pins of Ports 3 and 4 was reflected in IB 2.

To test digital I/O ports, we created testing loopbacks by connecting DIO 1 to 2, and DIO 3 to 4 with wires. Then we changed QB 0 to 2#0000\_1010, which set the DIO 2 and DIO 4 to high. IB 4 showed the input status of DIO 1-4 were high (2#0000\_1111).

Slot 5-8 (Port 5-8) and Slot 11 were open. They could be used by another IO controller via a second application relationship.

## 12.2 Read PDI Data as Record Data

For IO modules that have input data, the Port Qualifier and PDI data can also be read by using the SFB52 RDREC (read record). The following table shows the available record read indexes for the IO-Link Master.

### Available Record Read Index for MD 748I-11-42/L5-2222

Index	Description
100..131	1-32 byte of PDI data from an IO-Link Port module in Slot 1
200..231	1-32 byte of PDI data from an IO-Link Port module in Slot 2
300..331	1-32 byte of PDI data from an IO-Link Port module in Slot 3
400..431	1-32 byte of PDI data from an IO-Link Port module in Slot 4
500	1-4 byte of PDI data from a Port Status module in Slot 11
600	1-4 byte of PDI data from a Port Status module in Slot 12

*Available Record Read Index for MD 248i-12-8K/L4-2R2K*

Index	Description
100..131	1-32 byte of PDI data from an IO-Link Port module in Slot 1
200..231	1-32 byte of PDI data from an IO-Link Port module in Slot 2
300..331	1-32 byte of PDI data from an IO-Link Port module in Slot 3
400..431	1-32 byte of PDI data from an IO-Link Port module in Slot 4
500..531	1-32 byte of PDI data from an IO-Link Port module in Slot 5
600..631	1-32 byte of PDI data from an IO-Link Port module in Slot 6
700..731	1-32 byte of PDI data from an IO-Link Port module in Slot 7
800..831	1-32 byte of PDI data from an IO-Link Port module in Slot 8
900	1-4 byte of PDI data from a Port Status module in Slot 9
1000	1-4 byte of PDI data from a Port Status module in Slot 10
1100	1-4 byte of PDI data from a Port Status module in Slot 11

Using the same example in 12.1 Sample IO-Link Master Gateway Configuration; a record read request of 2-bytes at index 100 would return the current PDI data of the IO-Link device attached to Port 1. A record read request of 1-byte at Index 900 would return the current IO-Link port active status.

Reading partial PDI data via record read request is supported. For an instance, an IO-Link device that supports 32-bytes PDI data is connected to IO-Link Port 5. A record read request of 32-bytes at Index 500 returns the whole 32-bytes of PDI data. Another record read request of 4-bytes at Index 529 returns the last 4-bytes of the PDI data. This provides flexibility in being able to get only the interested data from a large PDI data block.

If a record read requests more data than the IO module or IO-Link device supports, IO-Link Master returns the available PDI data and fills the remaining data with zeros. Again using the same example in 12.1 Sample IO-Link Master Gateway Configuration; a record read request of 4-bytes at Index 100 returned 0x09 0x0E 0x00 0x00, where 0x09 and 0x0E were the actual PDI data.

IO-Link Master returns an error if a record read request contains an invalid index.

Writing PDO Data to an IO-Link device via data record write service is not supported. This is because that the new PDO data written by a record write will only last for one update cycle. The next cycle the IO controller overwrites the new PDO data with the old cyclic data from the process image.

**12.3 Using the SFB52 RDREC**

To use the SFB52 **RDREC**, specify the index of the requested module in **INDEX**. Specify the maximum number of bytes you want to read in **MLEN**. The selected length of the target area **RECORD** should have at least the length of **MLEN** bytes.

**TRUE** on output parameter **VALID** verifies that the data record has been successfully transferred into the target area **RECORD**. In this case, the output parameter **LEN** contains the length of the fetched data in bytes.

The output parameter **ERROR** indicates if a data record transmission error has occurred. In this case, the output parameter **STATUS** contains the error information.

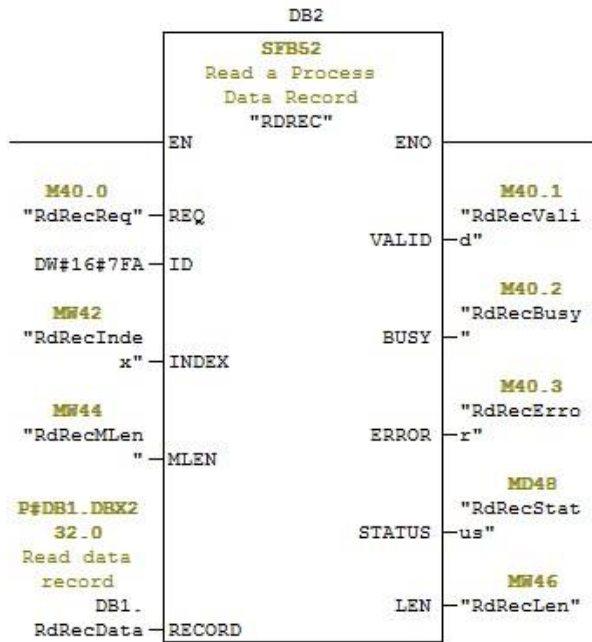

Figure 55: SFB52 Read a Process Data Record

### 12.4 Read and Write ISDU with the FB IOL\_CALL

The function block IOL\_CALL represents the conversion of the communication standardized for the IO-Link technology to and from IO-Link devices. The IO-Link Master supports the IOL\_CALL function block. It can be used to access an ISDU of an IO-Link device.

The IOL\_CALL function block and the library description are available at: <http://support.automation.siemens.com/WW/view/en/82981502>

To use IOL\_CALL function block, do the following:

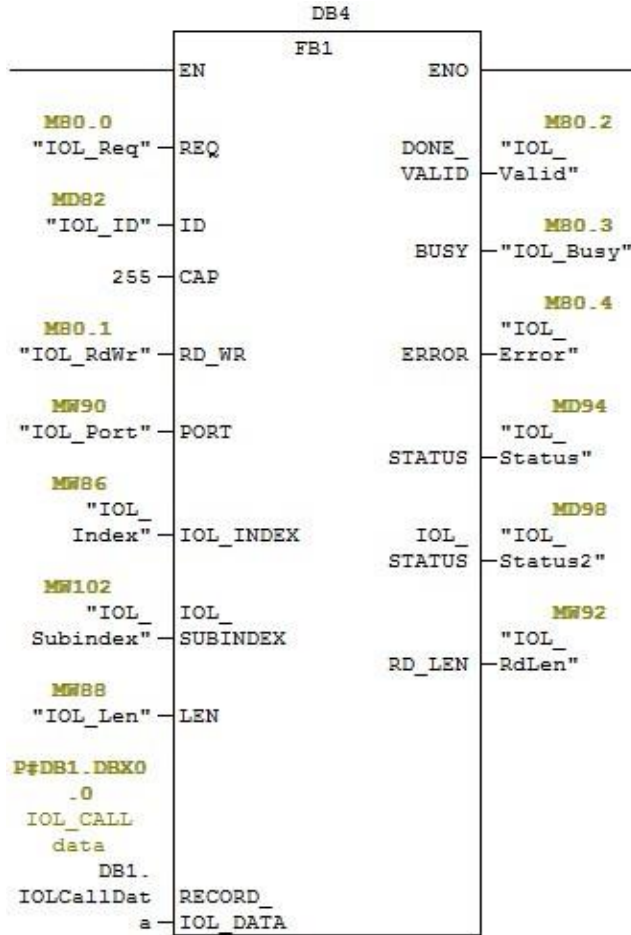

Figure 56: IOL\_CALL Function Block

1. Set **CAP** to 255.
2. Specify **PORT** to be the IO-Link port number (1 to 8) at which the IO-Link device is connected.
3. Set **IOL\_INDEX** and **IOL\_SUBINDEX** to be the index and subindex of the requested ISDU. **RECORD\_IOL\_DATA** requires the full specification of the DB parameters, i.e. **P#DB1.DBX0.0** byte 232. The target area **RECORD\_IOL\_DATA** must have enough available bytes to hold the requested ISDU block up to 232 bytes.
4. Set **RD\_WR** to 0 for read and 1 for write. For write, also specify the length of the data to be written in **LEN**. A positive edge on **REQ** starts the **IOL\_CALL** request.

**BUSY** is set to 1 when the **IOL\_CALL** request is in progress. Once completed, **DONE\_VALID** is set to 1 if there was no error. Otherwise, **ERROR** is set and **STATUS** and **IOL\_STATUS** contain the error information. For the remainder of the **IOL\_CALL** function block parameters and complete error information, refer to the **IOL\_CALL** library description.

Parameter	Description
CAP	Access point of the IOL_CALL function. Use 255.
PORT	IO-Link port number at which the IO-Link device is operated, port number 1 through 8. All other values: not supported.
IOL_INDEX	Address parameter INDEX (IO-Link device). 0 - 32767: index of ISDU
IOL_SUBINDEX	Address parameter SUBINDEX (IO-Link device). <ul style="list-style-type: none"> <li>• 0: not support</li> <li>• 1 - 255: subindex of ISDU</li> </ul>

The IOL\_CALL function block has a 20 seconds timeout value. If the request takes longer than 20 seconds, the process is aborted and a timeout error is returned. The IO-Link Master also has a timeout value for IOL\_CALL request. The default timeout value is 20 seconds. It can be changed through the web page (Configuration -> PROFINET IO).

## 12.5 Diagnostic Alarm

Events from IO-Link Master and IO-Link devices are mapped to PROFINET alarms and channel diagnostics according to the IO-Link on *PROFINET Working Document Version 13.4.2015* with some modifications.

### 12.5.1 IO-Link Event Mapping Overview

IO-Link events are mapped into **PROFINET Alarms and Channel Diagnostics** using the following table. Each appearing IO-Link event (mode Coming) results in adding channel diagnostics. Each disappearing IO-Link event (mode Going) results in removing channel diagnostics. IO-Link events that have mode Single will be mapped to PROFINET process alarm.

IO-Link Event Mapping	
IO-Link Event Mode	PROFINET
Single	Process alarm
Coming	Add channel diagnostics
Going	Remove channel diagnostics

In addition, only IO-Link events that have the type of Error or Warning are mapped to PROFINET channel diagnostics. Type Message IO-Link events are not mapped.

### 12.5.2 IO-Link EventCode Mapping

IO-Link events that are generated by IO-Link devices (remote events) are mapped to PROFINET diagnostics using **ChannelErrorType** 0x500 and 0x501.

- For an **EventCode** that is between 0x0000 and 0x7FFF, **ChannelErrorType** 0x500 is used. The **EventCode** is directly mapped to **ExtChannelErrorType**.
- For an **EventCode** that is between 0x8000-0xFFFF, **ChannelErrorType** 0x501 is used. The **EventCode** is mapped to **ExtChannelErrorType** with the MSB set to 0.
- For IO-Link events that are generated by IO-Link Master (local events), **ChannelErrorType** 0x502 is used.  
**EventCode** is directly mapped to **ExtChannelErrorType**.

The following table summarizes how IO-Link **EventCode** is mapped to PROFINET diagnostics.

IO-Link EventCode Mapping				
Source	EventCode	ChannelError Type	ExtChannel ErrorType	Comment
IO-Link Device (remote)	0x0000-0x7FFFF	0x500	0x0000-0x7FFFF	Direct mapping of <b>EventCode</b> to <b>ExtChannelErrorType</b> (e.g. <b>EventCode</b> 0x6321 will be mapped to <b>ExtChannelErrorType</b> 0x6321)
IO-Link Device (remote)	0x8000-0xFFFF	0x501	0x0000-0x7FFFF	Mapping of <b>EventCode</b> to <b>ExtChannelErrorType</b> . Set MSB ( <b>EventCode</b> ) to "0" (e.g. <b>EventCode</b> 0x8005 -> <b>ExtChannelErrorType</b> 0x0005)
IO-Link Master (local)	0x0000-0x7FFFF	0x502	0x0000-0x7FFFF	Direct mapping of local <b>EventCode</b> to <b>ExtChannelErrorType</b>

The following table lists some of the **EventCode** that the Leuze electronic IO-Link Master generates.

IO-Link EventCode	ExtChannelErrorType	Description
0x0001	0x0001	Slave PDU Flow
0x0002	0x0002	Master PDU checksum error
0x0003	0x0003	Slave illegal PDU
0x0004	0x0004	Master illegal PDU
0x0005	0x0005	Slave PDU buffer
0x0006	0x0006	Slave PD INKR
0x0007	0x0007	Slave PD length
0x0008	0x0008	Slave no PDI
0x0009	0x0009	Slave no PDO
0x000A	0x000A	Slave channel
0x000B	0x000B	Master event
0x000C	0x000C	Application message
0x000D	0x000D	Application warning
0x000E	0x000E	Application device
0x000F	0x000F	Application parameter
0x0010	0x0010	Slave device lost
0x0012	0x0012	Slave DESINA
0x001A	0x001A	Slave wrong sensor
0x001B	0x001B	Slave retry
0x001E	0x001E	Power short circuit
0x001F	0x001F	Power sensor
0x0020	0x0020	Power actuator
0x0021	0x0021	Power fault
0x0022	0x0022	Power reset
0x0023	0x0023	Slave fallback
0x0024	0x0024	Master preoperate
0x0028	0x0028	Data storage ready

IO-Link EventCode	ExtChannelErrorType	Description
0x0029	0x0029	Data storage identity fault
0x002A	0x002A	Data storage size fault
0x002B	0x002B	Data storage upload fault
0x002C	0x002C	Data storage download fault
0x002F	0x002F	Data storage device locked fault

The following image shows a *Slave device lost* event that was available in the diagnostics when an IO-Link device was disconnected from an IO-Link port. In the figure, Slot 2 means that the device was connected to IO-Link Port 2. The event will be removed from the diagnostics when the device is reconnected to the same IO-Link port.

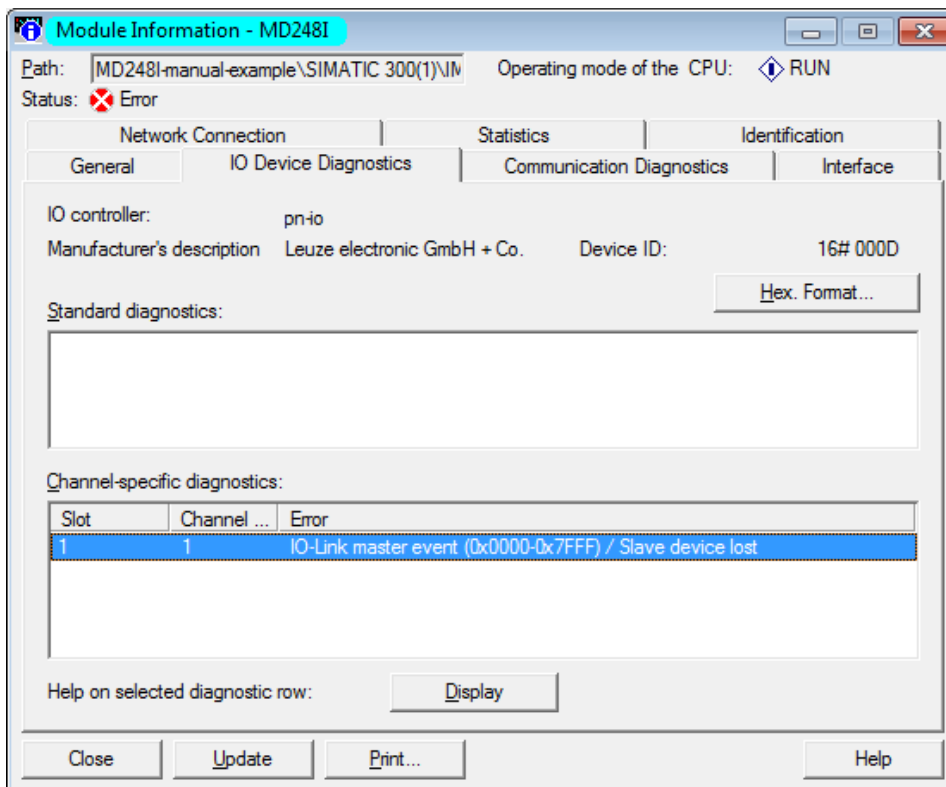

Figure 57: IO-Link Events through PROFINET Channel Diagnostics

## 13 Troubleshooting and Technical Support

This chapter provides the following information:

- *Troubleshooting*
- *IO-Link Master LEDs*
- *Contacting Technical Support*
- *Using Log Files*

### 13.1 Troubleshooting

Before contacting Technical Support, you may want to try the following:

- Check to make sure LEDs are not reporting an issue using IO-Link Master LEDs
- Verify that the network IP address, subnet mask, and gateway are correct and appropriate for the network. Make sure that the IP address programmed into the IO-Link Master matches the unique reserved IP configured address assigned by the system administrator.
  - If using DHCP, the host system needs to provide the subnet mask. The gateway is optional and is not required for a purely local network.
  - Remember that if the rotary switches on the MD 748I-11-42/L5-2222 are set to a non-default position, the rotary switches override the lower 3 digits (8 bits) of the static IP address configured in the **Network** page.
  - Verify that the Ethernet hub and any other network devices between the system and the IO-Link Master are powered up and operating.
- Verify that you are using the correct types of cables on the correct connectors and that all cables are connected securely.
- Disconnect and re-connect the IO-Link device, or optionally, use the **Configuration | IO-Link** page to **Reset** the port, and then set the **Port Mode** back to **IO-Link**.
- Reboot or power cycle the IO-Link Master. Use the **Advanced | Software** page to reboot the IO-Link Master.
- Verify that the **Port Mode** matches the device, for example: IO-Link, Digital In, Digital Out, or Reset (port is disabled).
- If you are receiving an error that indicates a hardware fault, check the **Configuration | IO-Link** page for the port experiencing the fault.
  - Check the settings for the **Automatic Upload Enable** and **Automatic Download Enable** options. If the Vendor ID or Device ID of the attached device does not match, a hardware fault is generated.
  - Make sure if the port contains data storage that the Vendor ID and Device ID match the device attached to the port. If it does not, **CLEAR** the data storage or move the device to another port.
  - Check the Device Validation and Data Validation settings. If the attached device does not meet these settings, a hardware fault is issued.
- Open the IO-Link Master web interface and review the following pages to see if you can locate a problem:
  - **IO-Link Diagnostics**
  - **Digital I/O Diagnostics**
  - **PROFINET IO**
- If you have a spare IO-Link Master, try replacing the IO-Link Master.

### 13.2 IO-Link Master LEDs

The following tables provide LED descriptions:

#### 13.2.1 MD 748i-11-42/L5-2222

The MD 748i-11-42/L5-2222 (4-port IP67 model) provides these LEDs.

<b>MD 748i-11-42/L5-2222 LEDs</b>	
PWR	A lit green <b>PWR</b> LED indicates that the IO-Link Master is powered.
MOD (Module Status)	<p>The <b>MOD</b> LED provides the following information:</p> <ul style="list-style-type: none"> <li>• Off = No errors or there is no PLC connection</li> <li>• Flashing red                             <ul style="list-style-type: none"> <li>• One or more errors detected when NET is off</li> <li>• Fatal error when NET is also flashing</li> </ul> </li> <li>• Steady red = Maintenance required or demanded</li> </ul>
NET (Network Status)	<p>The <b>NET</b> LED provides the following information:</p> <ul style="list-style-type: none"> <li>• Off = No PLC connection</li> <li>• Steady green = PLC connection established</li> <li>• Flashing red = Fatal error when MOD is also flashing</li> </ul>
1-4 	<p>This LED provides the following information about the IO-Link port.</p> <ul style="list-style-type: none"> <li>• Off: SIO mode - signal is low or disconnected.</li> <li>• Yellow: SIO mode - signal is high.</li> <li>• Flashing red: Hardware fault - make sure that configured IO-Link settings on the port do not conflict with the device that is attached:                             <ul style="list-style-type: none"> <li>• <b>Automatic Upload</b> and/or <b>Download</b> is enabled and it is not the same device.</li> <li>• <b>Device Validation Mode</b> is enabled and it is not the correct device.</li> <li>• <b>Data Validation Mode</b> is enabled but there is an error.</li> </ul> </li> <li>• Solid red - PDI of the attached IO-Link device is invalid.</li> <li>• Solid Green: An IO-Link device is connected and communicating.</li> <li>• Blinking Green: Searching for IO-Link devices.</li> </ul>
Ports 1-4 DI	<p>The <b>DI</b> LED indicates digital input on DI (Pin 2).</p> <ul style="list-style-type: none"> <li>• Off: DI signal is low or disconnected</li> <li>• Yellow: DI signal is high</li> </ul>
EIP 1 EIP 2	<p>The <b>EIP</b> LEDs provide the following information:</p> <ul style="list-style-type: none"> <li>• Green /Blinking = Activity</li> <li>• Green/lit LED = Link established</li> </ul>

**13.2.2 MD 248i-12-8K/L4-2R2K**

The MD 248i-12-8K/L4-2R2K (8-port IP20 DIN rail model) provides these LEDs.

<b>MD 248i-12-8K/L4-2R2K LEDs</b>	
PWR	A lit green <b>PWR</b> LED indicates that the IO-Link Master is powered.
MS (Module Status)	<p>The <b>MS</b> LED provides the following information:</p> <ul style="list-style-type: none"> <li>• Off = No errors or there is no PLC connection</li> <li>• Flashing green and red = Self-test</li> <li>• Flashing green = Standby – not configured</li> <li>• Steady green = Operational</li> <li>• Flashing red                             <ul style="list-style-type: none"> <li>• One or more errors detected when NS is off</li> <li>• Fatal error when NS is also flashing red</li> </ul> </li> <li>• Steady red = Maintenance required or demanded</li> </ul>
NS (Network Status)	<p>The <b>NS</b> LED provides the following information:</p> <ul style="list-style-type: none"> <li>• Off = No PLC connection</li> <li>• Flashing green and red = Self-test</li> <li>• Flashing green = An IP address is configured, but no connections are established</li> <li>• Steady green = PLC connection established</li> <li>• Flashing red = Fatal error when MS is also flashing</li> <li>• Steady red = Duplicate IP address on network</li> </ul>
Port 1-8	<p>This LED provides the following information about the IO-Link port.</p> <ul style="list-style-type: none"> <li>• Off: SIO mode - signal is low or disabled</li> <li>• Yellow: SIO mode - signal is high</li> <li>• Flashing red: Hardware fault - make sure that configured IO-Link settings on the port do not conflict with the device that is attached:                             <ul style="list-style-type: none"> <li>• <b>Automatic Upload</b> and/or <b>Download</b> is enabled and it is not the same device.</li> <li>• <b>Device Validation Mode</b> is enabled and it is not the correct device.</li> <li>• <b>Data Validation Mode</b> is enabled but there is an error.</li> </ul> </li> <li>• Solid red - PDI of the attached IO-Link device is invalid.</li> <li>• Solid Green: An IO-Link device is connected and communicating</li> <li>• Blinking Green: Searching for IO-Link devices</li> </ul>
D1-4	<p>The <b>D1 - D4</b> LEDs indicates digital input.</p> <p>Off: DI signal is low or disconnected</p> <p>On: DI signal is high</p>
Dual Ethernet Ports	<p>The Ethernet LEDs provide the following information:</p> <p>Green/Solid = Link</p> <p>Yellow/Solid = Activity</p>

**13.3 Contacting Technical Support**

You may want to access the **Help/SUPPORT** page when you call Technical Support, as they may request the information displayed on the **SUPPORT** page.

The screenshot shows the Leuze electronic web interface. At the top, there is a navigation menu with 'Home', 'Diagnostics', 'Configuration', 'Advanced', 'Attached Devices', and 'Help'. A user is logged in as 'Admin' with the IP '10.0.0.186'. The main content area is titled 'Support' and contains a table of system and application information. A 'DOWNLOAD' button is highlighted with a red box. At the bottom, a file save dialog box is open, asking to save 'supportinfo.txt' from '10.0.0.186'. The dialog has 'Open', 'Save', and 'Cancel' buttons.

SYSTEM INFO	
Host Name	?
Serial Number	9615-065532
Model Name	MD 748i-11-42/L5-2222
Hardware Version	99615-6 rev A
Switch Position	000
MAC Address	00:15:7b:84:07:f2
IP Address	10.0.0.186
Subnet Mask	255.255.0.0
Gateway Address	0.0.0.0
IP Type	static
APPLICATION BASE	
application-manager	1.4.0.0
configuration-manager	1.4.0.2
discovery-protocol	1.4.0.1
event-log	1.4.0.0
iolink-driver	1.4.2.7
iolink-manager	1.4.2.2
profinetio	1.4.1.10
web-help	1.4.0.1
web-user-interface	1.4.1.5
IMAGES	
U-Boot	1.18
FPGA	1.00
uImage-Primary	1.19
uImage-Backup	1.19
Applications	1.4.25

Figure 58: Saving device support information

Use the **Contact** page for information in the event you need technical assistance.

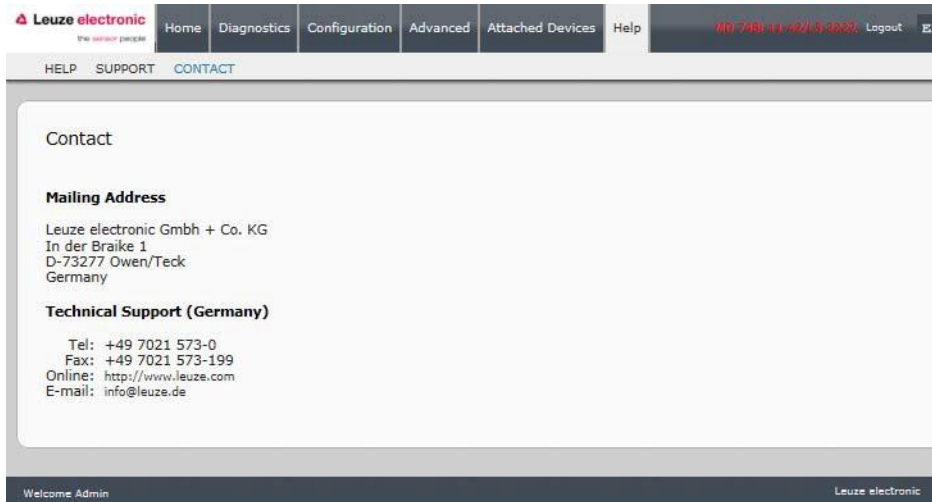

Figure 59: Support information

Reparaturservice und Rücksendungen:

Vorgehensweise und Internetformular finden Sie unter [www.leuze.de/reparatur](http://www.leuze.de/reparatur)

Rücksendeadresse für Reparaturen:

Servicecenter

Leuze electronic GmbH + Co. KG

In der Braike 1

D-73277 Owen / Germany

## 13.4 Using Log Files

The IO-Link Master provides five different log files that you can view, export, or clear:

- **Syslog** (system log) displays line-by-line activity records.
- **dmesg** displays Linux kernel messages.
- **top** displays which programs are using most of the memory and CPU.
- **ps** displays the running programs
- **pnio** displays PROFINET IO activity
- All log files start up automatically during the startup cycle. Each log file has a size limit of 100KB.

*Note:* Typically, log files are intended to be used by Technical Support in the event there is a problem.

You can use the following procedures to:

- *View a Log File*
- *Clear a Log File*
- *Export a Log File*

### 13.4.1 View a Log File

Use this procedure to view a log file.

1. Open the IO-Link Master web interface.
2. Click **Advanced** and then **LOG FILES**.
3. Select the log file type from the drop-list.
4. Optionally, click the **REFRESH** button to get the latest information.
5. Optionally, export the log file.

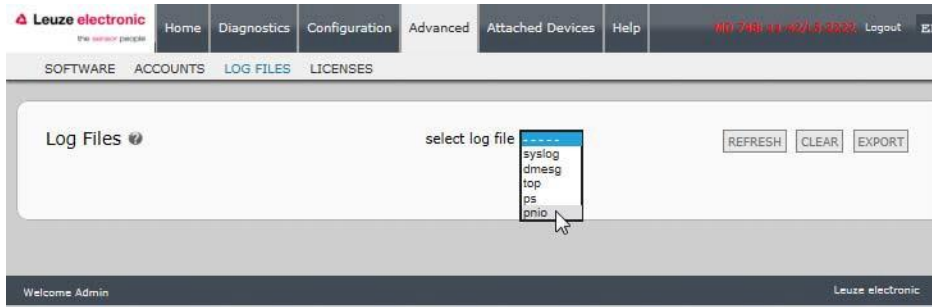

Figure 60: Select log file type

### 13.4.2 Export a Log File

Use the following procedure to export a log file.

1. Open the IO-Link Master web interface.
2. Click **Advanced** and then **LOG FILES**.
3. Select the log file type from the drop-list.
4. Click the **EXPORT** button.
5. Click the **Save** button drop-list and click **Save** to save it to your user folder or **Save as** to browse to or create a new folder in which to place the log file.

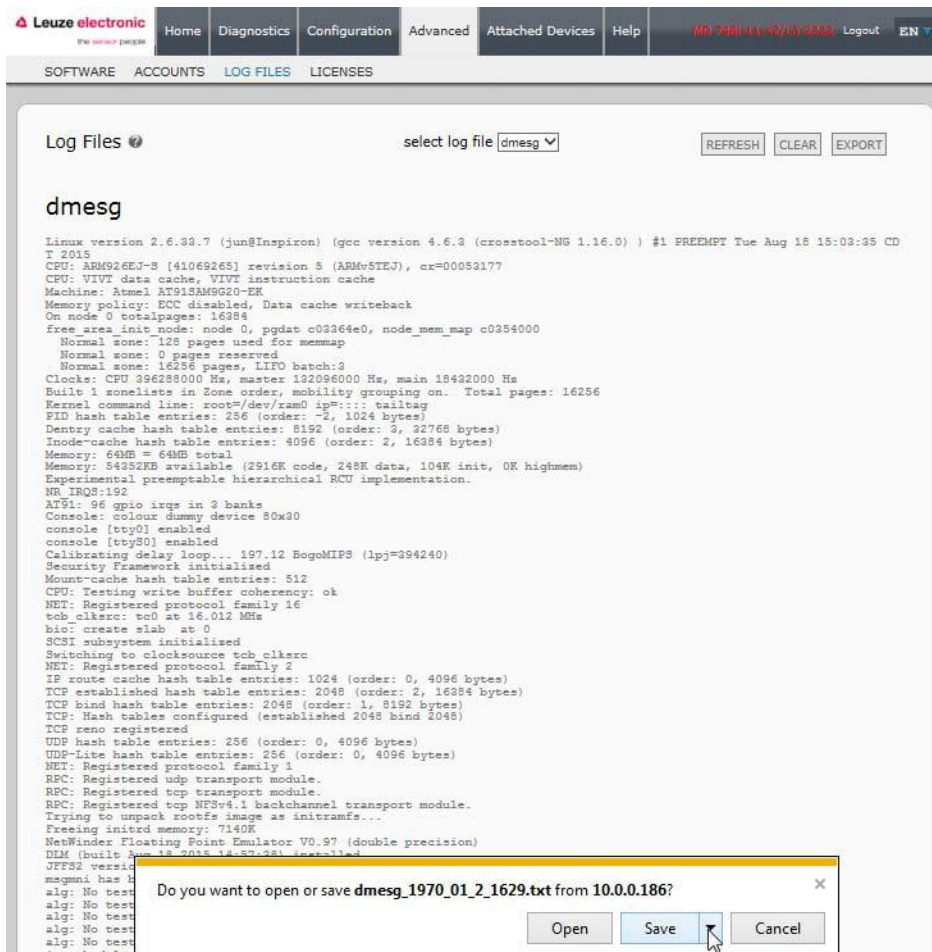

Figure 61: Save device log file

6. Depending on your operating system, you may need to close the pop-up window.

**13.4.3 Clear a Log File**

Use this procedure to clear a log file.

1. Open the IO-Link Master web interface.
2. Click **Advanced** and then **LOG FILES**.
3. Optionally, export the log file.
4. Select the log file type from the drop-list.
5. Click the **CLEAR** button.

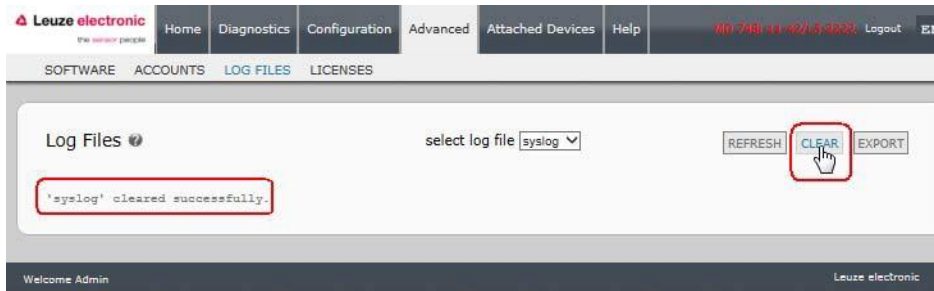

Figure 62: Clear log file

The log file automatically starts logging the latest information.

**14 TYPE / SPECIFICATION**

**14.1 MD 748i-11-42/L5-2222**

Part Nr. 50131482 MD 748i-11-42/L5-2222	
<b>HARDWARE</b>	
Enclosure	Molded ABS (potted)
Installation and Grounding Method	Machine or panel mount - two-hole M4 or #8 screws
Connectors	4 - IO-Link 2 - Ethernet 2 - Power
LED Indicators	Power, Module Status, Network Status, IO-Link, DI and Ethernet Port Status
Dimensions	6.07" x 2.04" x 1.68" 154 x 51.8 x 42.7 mm
<b>ETHERNET INTERFACE SPECIFICATIONS</b>	
Network Interfaces	10/100BASE-TX
Network Protocols	Profinet IO
Connector Type	Female, M12 D-coded, 4-pin
Number of Ports	2
Standards	IEEE802.3: 10BASE-T IEEE 802.3u: 100BASE-TX
Auto-MD/MDI-X	Yes
Auto-Negotiation	Yes
Link Distance	100 m
Cable Types	Unshielded twisted pair
IPv4 Addressing	Yes
<b>IO - LINK INTERFACE SPECIFICATIONS</b>	
Connector Type	Female, M12 D-coded, 4-pin
Number of Ports	4
Transfer Rates	4.8K (COM1) 38.4K (COM2) 230.4K (COM3)
Baud Rate Recognition	Automatic
Cable Length (Max.)	20m
<b>DIGITAL INPUTS</b>	
Connector Type	Female, M12 A-coded, 5-pin
Number of Ports	4
Input Characteristics	Type 2
Cable Length (Max.)	30 m
<b>DIGITAL OUTPUTS</b>	
Connector Type	Female, M12 A-coded, 5-pin
Number of Ports	4
Actuator (Sensor) Current Load (Max.)	500mA
Lamp Load (Max.)	4W

Over Load and Short Circuit Protection	Yes
Switching Output	PNP, NPN
<b>ELECTRICAL SPECIFICATIONS</b>	
Device	DC Input Voltage Range 18-30VDC Current Consumption (Max.) 2A @ 24VDC Current Consumption (w/out devices) 100mA Power Consumption 2.4W
Sensor Supply Connectors 1 to 4 (Max.)	500mA/connector
Power Connectors	Input (1) Male M12 A-coded 5-pin Output (1) Female M12 A-coded 5-pin
<b>ENVIRONMENTAL SPECIFICATIONS</b>	
Air Temperature	System On 0°C to +55°C* System Off -40°C to +70°C
Operating Humidity (non-condensing)	10% to 95%
Storage Humidity (non-condensing)	10% to 95%
Shock/Vibrations	EN60068-2-6 EN60068-2-27
Enclosure Rating	IP67 (IEC 60529)

**14.2 MD 248i-12-8K/L4-2R2K**

Part Nr.	50131483	MD 248i-12-8K/L4-2R2K
<b>HARDWARE</b>		
Enclosure	Polyamide	
Installation and Grounding Method	DIN rail	
Connectors	DI/DO, Ethernet, IO-Link, Power	
LED Indicators	Power, Module Status, Network Status, IO-Link, DI and Ethernet Port Status	
Dimensions	4.12" x 4.47" x 1.78" 105 x 114 x 45 mm	
<b>ETHERNET INTERFACE SPECIFICATIONS</b>		
Network Interfaces	10/100BASE-TX	
Network Protocols	Profinet IO	
Connector Type	RJ45	
Number of Ports	2	
Standards	IEEE802.3: 10BASE-T IEEE 802.3u: 100BASE-TX	
Auto-MD/MDI-X	Yes	
Auto-Negotiation	Yes	
Link Distance	100 m	
Cable Types	Unshielded twisted pair	
IPv4 Addressing	Yes	
<b>IO - LINK INTERFACE SPECIFICATIONS</b>		
Connector Type	Screw Terminal	

Number of Ports	8
Transfer Rates	4.8K (COM1) 38.4K (COM2) 230.4K (COM3)
Baud Rate Recognition	Automatic
Cable Length (Max.)	20m
<b>DIGITAL INPUTS</b>	
Connector Type	Screw Terminal
Number of Ports	2
Input Characteristics	Type 2
Cable Length (Max.)	30 m
<b>DIGITAL OUTPUTS</b>	
Connector Type	Screw Terminal
Number of Ports	4
Actuator (Sensor) Current Load (Max.)	500mA
Lamp Load (Max.)	4W
Over Load and Short Circuit Protection	Yes
Switching Output	PNP, NPN
<b>ELECTRICAL SPECIFICATIONS</b>	
Device	DC Input Voltage Range 18-30VDC Current Consumption (Max.) 2A @ 24VDC Current Consumption (w/out devices) 100mA Power Consumption 2.4W
Sensor Supply Connectors 1 to 4 (Max.)	500mA/connector
Power Connectors	Input (1) Screw Terminal Output (1) Screw Terminal
<b>ENVIRONMENTAL SPECIFICATIONS</b>	
Air Temperature	System On 0°C to +70°C* System Off -40°C to +70°C
Operating Humidity (non-condensing)	10% to 95%
Storage Humidity (non-condensing)	10% to 95%
Shock/Vibrations	EN60068-2-6 EN60068-2-27
Enclosure Rating	IP67 (IEC 60529)